

V-9502 Series Pneumatic Valve Actuator Positioners

V-9502 Series Pneumatic Valve Actuator Positioners are precision relay devices designed to operate pneumatic valve actuators in applications requiring stable, accurate control. These positioners provide maximum positioning power to resist external forces that might otherwise overcome the positioning power of the actuator. Adjustable operating span (on all pneumatic valve actuators except the V-3000 Series) and starting point also make the V-9502 ideal for valve sequencing applications.

The V-9502 Series can be mounted directly to V-3000 Series, 3R, 4R, 5R, 8R, or MP8000 Series pneumatic valve actuators. In many instances, the positioner can be ordered factory installed on these actuator and valve assemblies.



**Figure 1: V-9502 Series
Pneumatic Valve Actuator Positioner Installed on
a Typical V-3000 Type Valve Actuator (Left) and
Rubber Diaphragm Type Valve Actuator (Right)**

Features and Benefits	
<input type="checkbox"/> Maximum Positioning Power	Compensates for flow surges in the piping system, and holds the valve at the position dictated by the controller
<input type="checkbox"/> Field-Selectable Operating Span (All Pneumatic Valve Actuators Except V-3000 Series)	Allows for easy valve sequencing from a single control signal
<input type="checkbox"/> Field-Adjustable Starting Point	Tailors the starting point in order to provide accurate control
<input type="checkbox"/> Expanded Usability	Provides application flexibility since models can be mounted directly to V-3000 Series, 3R, 4R, 5R, 8R, and MP8000 Series Pneumatic Valve Actuators

Operation

Feedback from the actuator stem (through the positioner spring and lever arm assembly) activates the V-9502 Pneumatic Valve Actuator Positioner to compensate for flow surges in the piping system and holds the valve at the position dictated by the controller. The V-9502 modulates the stroke of the actuator in relation to a pressure change from the controller.

Supply air enters the control chamber of the relay and is admitted to the actuator when the control pressure in the pilot chamber exceeds the preestablished starting point. This pressure causes the actuator stem to move. Movement of the stem is fed back to the relay through the positioner spring and lever arm assembly, to impose a balancing force against the control pressure. When all forces are in balance, the V-9502 does not allow supply air to pass through to the actuator. The actuator establishes a position that is proportional to the value of the pressure from the controller. Any change in stem position unbalances the relay. As a result, air pressure in the actuator increases or is exhausted in order to reestablish a balance at the desired stem position.

Operating Range

The span and starting point adjustments of the V-9502 Pneumatic Valve Actuator Positioner determine the operating range. The lower value of the operating range is the control signal pressure at which the actuator just begins to stroke. The upper value of the operating range is the control signal pressure at which the actuator reaches its maximum stroke. The difference between the upper and lower values of the control signal pressure is the operating span.

Operating Span

The operating span of the V-9502 Pneumatic Valve Actuator Positioner is field selectable from 3 to 13 psi (21 to 90 kPa) on 3R, 4R, 5R, 8R, and MP8000 Series pneumatic valve actuators. The operating span is determined by the location of the spring in the positioner operating span lever arm (as illustrated in Figure 2). When the spring is installed in the hole closest to the V-9502 Positioner cover, the spring allows a span of 3 psi (21 kPa). When the spring is installed in the hole farthest from the positioner cover, the spring allows a span of 13 psi (90 kPa).

The operating span for V-3000 Series Pneumatic Valve Actuators is determined by the positioner spring used with the actuator. To change the operating span, simply select a different positioner spring from Table 9 or 10. In all instances, the spring should be installed in the hole on the operating span lever arm that is farthest from the positioner body.

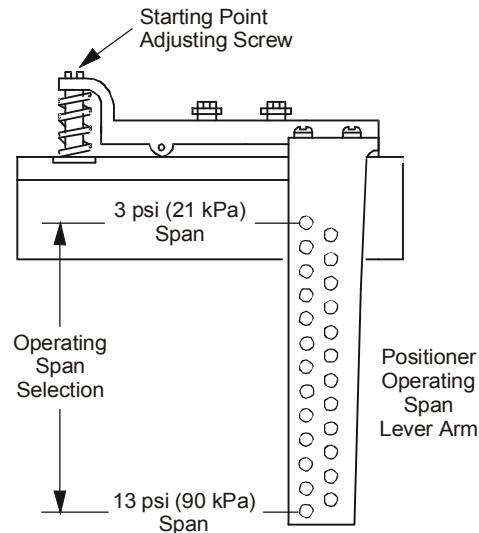

Figure 2: V-9502 Series Pneumatic Valve Actuator Positioner with Cover Removed

Starting Point

The starting point is the input pressure (Pilot P pressure) at which the actuator just begins to stroke. The starting point is field adjustable from 2 to 12 psig (14 to 83 kPa) using the starting point adjusting screw located under the V-9502 Positioner cover (as illustrated in Figure 2). Turning the screw clockwise decreases the starting point and turning the screw counterclockwise increases the starting point.

Note: The sum of the starting point pressure and the operating span must not exceed the supply air pressure to the V-9502 Pneumatic Valve Actuator. A nominal supply pressure is typically between 20 and 25 psig (138 and 172 kPa). Be certain to maintain a starting point pressure and corresponding operating span accordingly.

Mounting Methods

Most V-9502 Pneumatic Valve Actuator Positioners are furnished with a mounting bracket for attachment directly onto the actuator yoke. For V-3000 Series Pneumatic Valve Actuators, the V-9502 Positioner is installed directly onto the side of the actuator. Regardless of the actuator chosen, be certain to allow enough clearance for removal of the V-9502 Positioner cover and adjustment of the relay.

When a pneumatic actuated valve assembly is ordered with a V-9502 Positioner, the positioner is factory installed on the actuator (refer to the appropriate valve product bulletin for more details).

Table 1: Models and Ordering Information

Valve Type	Stem Diameter, in. (mm)	Diaphragm Size	Code Number
V-5250, V-5460, V-5650, V-5840 Valves	1/4 (6)	3R	V-9502-1*
	1/4 (6)	4R	V-9502-2*
	5/16 (8)	4R	V-9502-3*
	5/16 (8)	5R	V-9502-4*
	3/8 (10)	5R	V-9502-5*
	1/2 (13)	8R	V-9502-6*
V-3000-8011 Actuated Valves	---	---	V-9502-90*
V-3000-8001 Actuated Valves	---	---	V-9502-91*
V-3000-1 Actuated Valves	---	---	V-9502-15*
MP8000 Actuated VG2000 and VG7000 Series Valves	---	---	V-9502-95**
V-5252, V-5254, V-5462, V-5464, V-5652, V-5842, V-5844 Valves	All	All	V-9502-23*
V-5210, V-5216, V-5230, V-5410, V-5416, V-5430, V-5810, V-7216, V-7416 Valves	All	4R, 5R, 8R	V-9502-16*
V-400 and V-500 Actuated Valves	---	---	V-9502-76***
V-3000 Actuated V-7216 and V-7416 Valves	---	---	V-9502-8033*

* Positioner kit includes positioner, interconnecting linkage, and mounting hardware (order positioner spring separately; refer to Tables 6, 9, and 10 for more details).

** Positioner kit does not include positioner spring or mounting hardware (order positioner spring and mounting kit separately; refer to Table 7 for more details).

*** Positioner kit does not include positioner spring (order positioner spring separately; refer to Table 8 for more details).

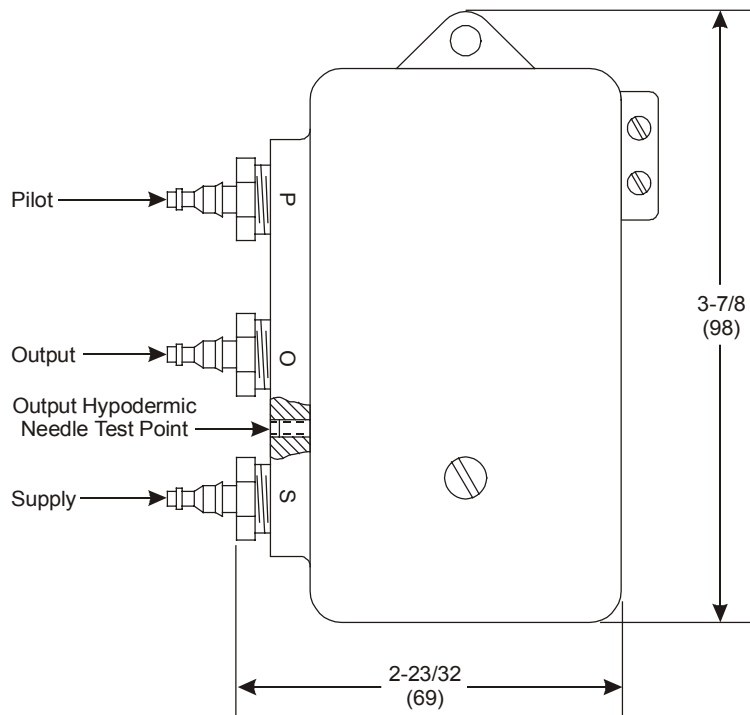

Figure 3: V-9502 Port Identification and Dimensions, in. (mm)

Table 2: Valve Strokes for All Valves Except Encapsulated Spring Models in Tables 3 through 5

Valve Size, in.	Valve Type	Valve Stroke, in. (mm)
1/2 and 3/4	VG7000 Series Valves	5/16 (8)
1 and 1-1/4	VG7000 Series Valves	1/2 (13)
1-1/2 and 2	VG7000 Series Valves	3/4 (19)
1/2 and 3/4	All Except V-3754, V-3974, V-4324, V-4440, and VG7000 Series Valves	5/16 (8)
1 and 1-1/4	All Except V-3754, V-3974, V-4324, V-4440, and VG7000 Series Valves	3/8 (10)
1/2 and 3/4	V-3754, V-3974, and V-4324 Valves	1/2 (13)
1/2 and 5/8	V-4440 Valves	11/16 (17)
1	V-3754, V-3974, and V-4324 Valves	3/4 (19)
1-1/2 and 2	All Angle, Globe, and Three-Way Mixing Valves Except V-3754, V-3974, V-4324, V-5254, V-5464, and V-5844	1/2 (13)
1-1/2 and 2	V-3754, V-3974, V-4324, V-5254, V-5464, and V-5844 Valves	3/4 (19)
2-1/2	Two-Way Normally Open (N.O.) and Normally Closed (N.C.) Valves	3/4 (19)
	Three-Way Mixing and Bypass Valves*	3/4 (19)
	Three-Way Mixing and Bypass Valves	9/16 (14)
3	Two-Way N.O. and N.C. Valves	7/8 (22)** and 1-1/8 (29)
	Three-Way Mixing and Bypass Valves*	7/8 (22)
	Three-Way Mixing and Bypass Valves	13/16 (21)
4	Two-Way N.O. and N.C. Valves	1-1/8 (29)
	Three-Way Mixing and Bypass Valves*	1-1/8 (29)
	Three-Way Mixing and Bypass Valves	1 (25)
5	Two-Way N.O. and N.C. Valves	1-3/8 (35)
	Three-Way Mixing and Bypass Valves*	1-3/8 (35)
	Three-Way Mixing and Bypass Valves	1-3/16 (30)
6	Two-Way N.O. and N.C. Valves	1-1/2 (38)
	Three-Way Mixing and Bypass Valves*	1-1/2 (38)
	Three-Way Mixing and Bypass Valves	1-7/16 (37)
8	Two-Way N.O. and N.C. Valves	1-1/2 (38)
	Three-Way Mixing Valves	2 (51)

* For V-5850, V-5852, and V-5820 Series valves only

** With 4R top

Table 3: Valve Strokes for V-5252, V-5254, V-5462, V-5464, V-5652, V-5842, and V-5844 Valves

Valve Size, in.	Valve Stroke, in. (mm)
1-1/4	3/8 (10)
1-1/2 and 2*	1/2 (13)
2-1/2	3/4 (19)
3 (4R)	3/4 (19)
3 (5R and 8R)	1-1/8 (29)
3 (V-5652)	7/8 (22)
4	1-1/8 (29)
5	1-3/8 (35)
6	1-1/2 (38)

* V-5254, V-5464, and V-5844 Series valves have a stroke of 3/4 in. (19 mm).

Table 4: Valve Strokes for V-5210, V-5216, V-5410, V-5416, V-5810, V-7216, and V-7416 Valves

Valve Size, in.	Valve Stroke, in. (mm)
1/2	5/16 (8)
3/4 and 1	3/8 (10)
1-1/4, 1-1/2, and 2	1/2 (13)
2-1/2	3/4 (19)
3 and 4	1-1/8 (29)

Table 5: Valve Strokes for V-5230 and V-5430 Valves

Valve Size, in.	Valve Stroke, in. (mm)
1/2 and 3/4*	5/16 (8)
1 and 1-1/4	3/8 (10)
1-1/2 and 2	1/2 (13)

* Up to Cv = 4.7

Table 6: Positioner Springs for 3R, 4R, 5R, and 8R Pneumatic Valve Actuators, or Kieley & Mueller Actuator and Valve Assemblies Manufactured Prior to January, 1975

Valve Stroke, in. (mm)	Code Number
3/16 through 5/16 in. (5 through 8 mm)	V-510-100
3/8 through 7/16 in. (10 through 11 mm)	V-510-101
15/32 through 5/8 in. (12 through 16 mm)	V-510-102
11/16 through 3/4 in. (17 through 19 mm)	V-510-103
13/16 through 1-1/4 in. (21 through 32 mm)	V-510-104
1-3/8 through 1-1/2 in. (35 through 38 mm)	V-510-105
1-5/8 through 2 in. (41 through 51 mm)	V-510-106
2-3/8 through 2-1/2 in. (60 through 64 mm)	V-510-107

Table 7: Positioner Springs for MP8000 Actuated VG2000 and VG7000 Series Valves

Valve Stroke, in. (mm)	Positioner Spring Color Code	Code Number
5/16 (8)	Yellow	V-9502-610
1/2 (13)	Blue	V-9502-611
3/4 (19)	White	V-9502-612
1 (25)	Gray	V-9502-613
1-1/4 (32)	Green	V-9502-614
1-1/2 (38)	Red	V-9502-615
All	All	MP8000-6002*

* Kit includes all mounting hardware and all six color-coded positioner springs.

Table 8: Positioner Springs for V-400 and V-500 Actuated VG7000 Series Valves

Valve Size, in.	Valve Stroke, in. (mm)	Code Number
1/2 or 3/4	5/16 (8)	V-9502-8100
1 or 1-1/4	1/2 (13)	V-9502-8102
1-1/2 or 2	3/4 (19)	V-9502-8106

Table 9: Positioner Springs for V-3000 Actuated VG7000 Series Valves

Valve Stroke, in. (mm)	5/16 (8)	3/8 (10)	1/2 (13)	3/4 (19)	Code Number
Spring Span, psig (kPa)	3.0 (21)	---	5.0 (34)	10.0 (70)	V-9502-6801
	8.0 (55)	---	12.0 (83)	---	V-9502-6802
	---	---	---	4.0 (28)	V-9502-6803

Table 10: Positioner Springs for All Other V-3000 Actuated Valves Except VG7000 Series

Valve Stroke, in. (mm)	5/16 (8)	3/8 (10)	1/2 (13)	3/4 (19)	Code Number
Spring Span, psig (kPa)	8.0 (55)	9.5 (65)	12.0 (83)	---	V-9502-19
	3.0 (21)	4.0 (28)	5.0 (34)	---	V-9502-20
	---	---	3.6 (25)	5.1 (35)	V-9502-100
	4.3 (30)	5.2 (36)	7.0 (48)	10.6 (73)	V-9502-101

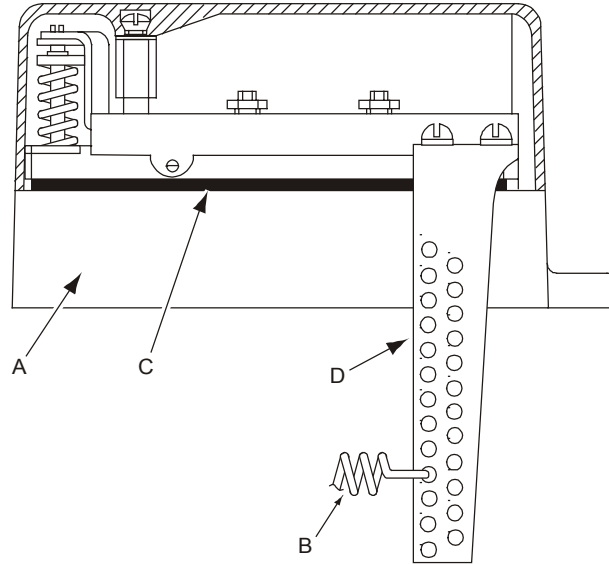

**Figure 4: V-9502 Series
Pneumatic Valve Actuator Positioner Repair Parts**

Table 11: V-9502 Series Pneumatic Valve Actuator Positioner Repair Parts

Item	Description	Shipping Weight, lb*	Code Number
A	Positioner Movement Complete (Less Items B and D)	1.5	C-9506-1
B	Positioner Springs (Refer to Tables 6 through 10.)	---	---
C	Diaphragm Assembly: Includes Diaphragm, Six Diaphragm Reinforcements, One Seat, Three Nuts, One Spring, Two Metal Balls, One Ball Retainer, Two Screws, and One Gasket.		
	For Old-Style Positioners with Air Connections on Three Sides	0.03	V-9502-600
	For New-Style Positioners with Air Connections on One Side	0.03	D-9502-611
D	Positioner Operating Span Lever Arm Assembly	0.01	D-9502-604

* lb x 0.454 = kg.

Technical Specifications

Product	V-9502 Series Pneumatic Valve Actuator Positioners	
Models and Ordering Information	Refer to Table 1.	
Operating Span	Field Selectable from 3 to 13 psi (21 to 90 kPa) on 3R, 4R, 5R, 8R, and MP8000 Series Pneumatic Valve Actuators; Fixed on V-3000 Series Pneumatic Valve Actuators	
Starting Point	Field Adjustable from 2 to 12 psig (14 to 83 kPa)	
Supply Pressure	20 psig (138 kPa) Nominal; 25 psig (172 kPa) Maximum	
Air Consumption	5 scim (1.4 mL/s)	
Output Flow Capacity	With Dual Barbed Fitting	1,000 scim (273 mL/s)
	With 1/4 in. Fitting	1,600 scim (437 mL/s)
Air Connections	1/8 in. NPT Dual Barbed Fittings for 5/32 or 1/4 in. O.D. Poly tubing	
Ambient Operating Temperature Limits	-20 to 150°F (-29 to 66°C)	
Materials	Body	Die Cast Aluminum with Iridite Finish
	Cover	Noryl® Plastic
	Diaphragm	Fabric-Reinforced Rubber
Shipping Weight	2.0 lb (0.9 kg)	

The performance specifications are nominal and conform to acceptable industry standards. For application at conditions beyond these specifications, consult the local Johnson Controls office. Johnson Controls, Inc. shall not be liable for damages resulting from misapplication or misuse of its products.



Controls Group
507 E. Michigan Street
P.O. Box 423
Milwaukee, WI 53201

Published in U.S.A.
www.johnsoncontrols.com