

ARMflo five turn venturi

Circuit balancing valves

Installation and operating instructions

File No: 36.89

Date: DECEMBER 20, 2017

Supersedes: 36.89

Date: NOVEMBER 27, 2017

—

—

—

—

CONTENTS

1.0	Typical applications	4
2.0	Installation	4
	Sweat (solder) connections	5
	Threaded connections	5
	Operation	5
	Memory setting	7
3.0	Troubleshooting	8

1.0 TYPICAL APPLICATIONS

Armstrong circuit balancing valves are most often used in hydronic heating and cooling installations, using a recirculating liquid as the heat transfer medium. Suitable liquids include water, glycol-water mixtures (both ethylene and propylene glycols), and brine. For applications or liquids other than those listed, please call Armstrong technical support for recommendations.

TECHNICAL DATA

Product is in compliance with **lead free** pipe, pipe fittings, plumbing fittings or fixtures, as defined by CA, LA, MD, VT state laws and the U.S. Safe Water Drinking Act.



- Connection:** Model CBV-VS - Solder joint
- Model CBV-VT - Threaded NPT
- Model CBV-VB - Threaded BSPP (ISO-228)

Maximum working pressure: 300 psi / 20 bar (PN20)
Operating Temperature Range: -4°F to 300°F (-20°C to 150°C)

MATERIALS OF CONSTRUCTION

- Body, Bonnet:** Brass alloy CW617
- Stem/Disk:** BRASS-C46500
- Handwheel:** Reinforced nylon; ABS
- Elastomers:** EPDM

MAXIMUM OPERATING PARAMETERS

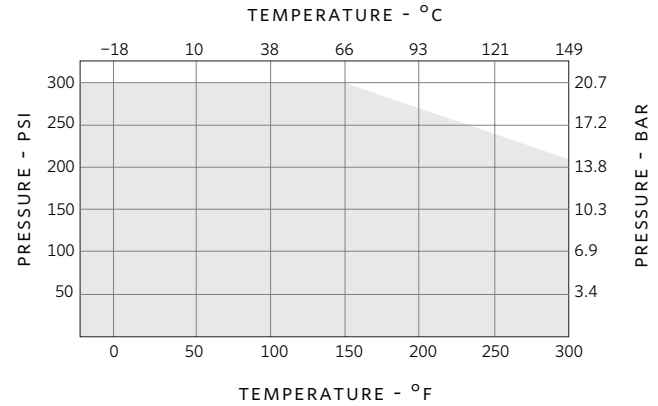

FLOW RATE RANGES					
VALVE MODEL	VALVE SIZE		MIN. FLOW	MAX. FLOW	VENTURI FLOW COEFFICIENTS
	IMPERIAL	METRIC	Usgpm(l/s)	Usgpm(l/s)	Cv(Kv)
CBV050V(x)CR-LF	½" LF	DN15 LF	0.26 (0.02)	1.98 (0.12)	0.69 (0.59)
CBV075V(x)CR-LF	¾" LF	DN20 LF	0.41 (0.03)	3.11 (0.20)	1.08 (0.93)
CBV050V(x)CR	½"	DN15	1.22 (0.08)	9.57 (0.60)	3.20 (2.74)
CBV075V(x)CR	¾"	DN20	1.99 (0.13)	13.76 (0.87)	5.21 (4.47)
CBV100V(x)CR	1"	DN25	4.57 (0.29)	22.97 (1.45)	12.01 (10.29)
CBV125V(x)CR	1¼"	DN32	6.17 (0.39)	38.00 (2.39)	16.19 (13.88)
CBV150V(x)CR	1½"	DN40	9.02 (0.57)	50.07 (3.15)	23.69 (20.30)
CBV200V(x)CR	2"	DN50	15.50 (0.98)	81.92 (5.16)	40.70 (34.88)

NOTES: Where Model (x) = Connection Type: T = NPT, S = Sweat, B = BSPP (ISO-228).

2.0 INSTALLATION

- 1 Clean debris and other contaminants from the system piping (pipe scale, rust, welding slag). As with any water system it is important to make provisions to keep the system clean. For optimum operation air trapped in the fluid must be removed.
- 2 The operation of the valve is dependent on the fluid's characteristics (such as specific gravity and viscosity) which vary with the fluid temperature. For installations using fluids other than 100% water, flow rates must be corrected for the changes created by the fluid medium. See www.armstrongfluidtechnology.com for appropriate correction factors, or call your local Armstrong representative.

- 3 To ensure accuracy of measurement Circuit Balancing Valves (cbv's) should be located at least five pipe diameters downstream from any fitting and at least ten pipe diameters downstream from a pump (as illustrated in **FIG. 1**).

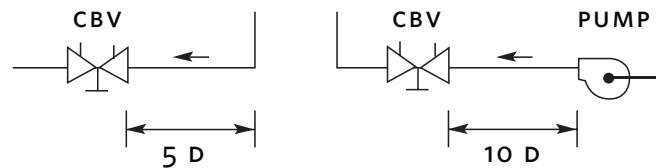

FIG. 1

- 4 All cbv's are marked with an arrow on the valve body to indicate direction of flow. The arrow must point in the direction of flow for proper operation.

- 5 CBV's may be installed in horizontal or vertical piping (as illustrated in **FIG. 2**). Provisions must be made for easy access to the probe metering ports (PMP's), reading scale, and memory stop.

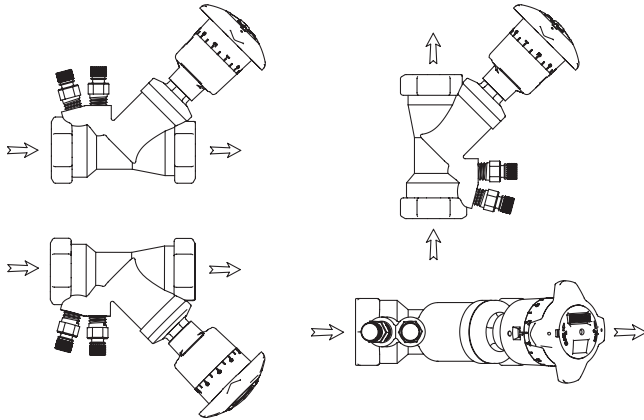

FIG. 2

SWEAT (SOLDER) CONNECTIONS

- 6 CBV-VS models are supplied with sweat style connections. Caution should be used when sweat style connection valves are installed to prevent overheating the valve.
- 7 Solder the valve body in line using 95/5 (95% tin, 5% antimony) type solder or equal. Always follow local plumbing codes for installation best practices.

CAUTION



Before soldering, ensure the valve is opened at least one full turn to avoid damage to the sealing O-ring due to overheating.

Armstrong recommends that the CBV be protected during installation by wrapping a damp rag around the handle/bonnet assembly prior to soldering the valve into the line.

THREADED CONNECTIONS

- 8 CBV-VT models are tapped with NPT threaded connections. CBV-VB models are tapped with BSP threaded connections. All threaded connections should be sealed using an approved pipe sealant per industry standards. Once the CBV installation has been completed and the system has been filled and purged, each valve loop must be adjusted to the correct flow setting. Employ piping best practice when engaging pipe to threaded valves. Overtightening when installing valves may result in fracturing of the valve body at the threads.

WARNING



Armstrong does **not** recommend leak testing an HVAC system with air due to safety concerns. Testing HVAC systems with pressurized air can be dangerous due to the high compressibility of air, as compared to water.

OPERATION

- 9 Armstrong circuit balancing valves are selected to deliver the correct flow in a piping circuit based on the line size and design flow rate.
- 10 To set the system flow, adjust the handwheel position until the differential pressure reading across the venturi corresponds to the required GPM.
- 11 The valve operates from fully open to closed by a clockwise rotation of the red handwheel using five 360° turns. Two indicators describe the position of the valve: the handwheel turns dial and the micrometer scale.

- **'Handwheel turns' dial:** This dial is printed on the outer surface of a gearing mechanism located inside the lower half of the handle assembly (**FIG. 6**). Each complete 360° revolution of the handwheel is visible through a display window and is scaled 0 - 5 to indicate the valve position in terms of the number of full turns. (**FIG. 3**)
- **Micrometer scale:** This scale is marked 0 - 9 and is located on the upper half of the handle assembly. Each mark represents $\frac{1}{10}$ th of a full, 360° turn of opening when lined up with an arrowhead symbol, located above the handwheel turns display window. (**FIG. 3**)

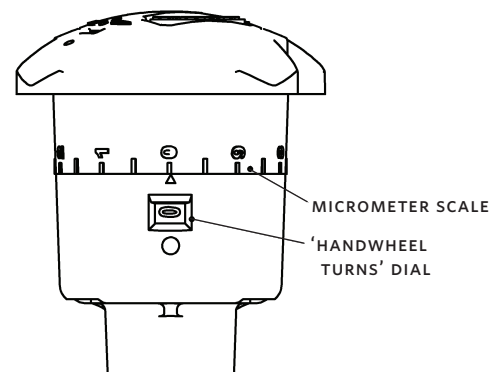

FIG. 3: CBV setting of 0.0 indicates that the valve is closed. Both the handwheel turns dial and the micrometer scale indicate a valve position reading of 0.

- 12 The valve is considered 'zeroed' when fully closed hand tight. The '0' on the micrometer scale should be within one half of $\frac{1}{10}$ th of a turn of the arrowhead symbol when the valve is closed hand tight. **Do not use a wrench on these valves - they should be opened and closed by hand only!**

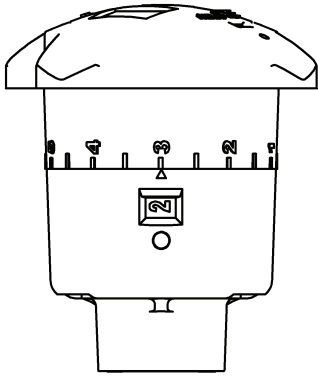

FIG. 4: cbv setting of 2.3 indicates that the valve is partially open (2.3 turns open).

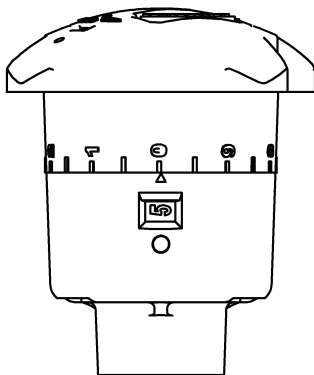

FIG. 5: cbv setting of 5.0 indicates that the valve is fully opened. In some cases, the valve may open as much as 5.3 turns, due to the depth of the stem threads. This is not a problem with the valve; however, the performance curves for these cbvs are calibrated only to 5.0 turns.

CAUTION



Hot water leakage can occur from metering ports (PMP's) during probe insertion and hookup of metering device. Wear protective eyewear and clothing to prevent personal injury when measuring pressure.

- 13 Connect pressure measuring device to the cbv metering ports as follows:

- Remove protective cap from metering ports ($\frac{1}{4}$ " NPT connection).
- Insert the meter probe into the metering ports. The hose with red fitting, up stream; the hose with blue fitting downstream.

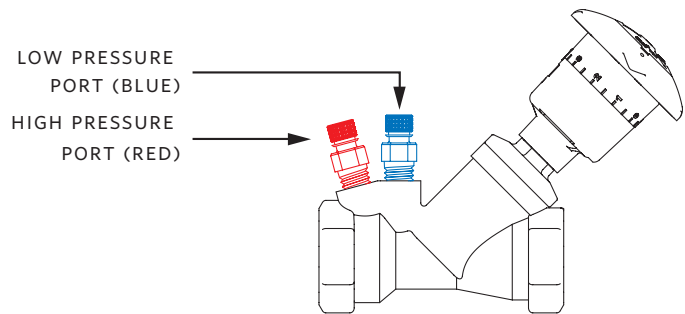

CAUTION



When inserting probe, do not bend, as this will cause permanent damage to the probe, adversely affecting the pressure measurement. Do not use any lubrication on the probes when inserting them. If necessary, simply wet the probes with clean water.

The probe should not be left inserted into the fitting for prolonged periods of time, overnight, etc., as leakage of the PMP may occur when the probe is removed.

The locking nut on the probe is designed to hold it in the PMP when taking readings. As sealing is accomplished internally on the probe stem, it is only necessary to tighten the locking nut **finger-tight**. Over-tightening may cause damage to the PMP or locking nut threads.

- 14 Before taking a measurement reading, set the valve to its fully open position (5.0) or at a preset position. Read the pressure drop across the venturi with an Armstrong cbDM or digital meter. Using the cbv rule, turn the wheel of the slide rule until the measured pressure drop appears in window. Read the flow for the particular size of valve installed.
- 15 The handle of the Armflo cbv is not designed to be removeable. If, for any reason, the handle is damaged and requires replacement, please order replacement handle kit 871159-099.

MEMORY SETTING

16 After valve has been properly adjusted and without moving the handwheel, the locking memory stop should be set. The memory stop will allow the valve to be fully closed for isolation and then reopened to the preset flow position.

17 Insert a 2.5 mm (or 3/32") Allen key through the hole provided in the valve's handle cap. (FIG. 6)

18 Turn the setscrew in a clockwise direction until it stops. It is not necessary to tighten. The memory has now been set. This establishes the maximum opening position for this particular valve.

19 The valve may now be closed tightly, as needed, for isolating the piping during system maintenance.

To return the valve to its preset "balanced" position, simply open the valve by turning the handwheel counter-clockwise until the handle stops turning (the valve stem inside the

handle has hit the memory setscrew). **Do not apply excessive force when reopening the valve - open only until the valve stops turning under 'hand-tight' conditions. Do not use a wrench to open, close, or tighten the valves.**

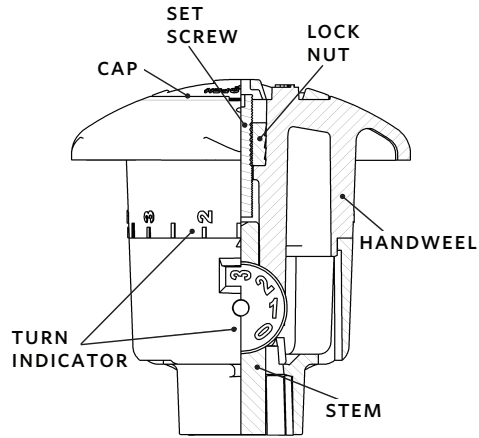

FIG. 6

VENTURI C_v PERFORMANCE CURVES

CBV - DZR 1/2" TO 2" HEAD LOSS (5 TURNS OPEN)

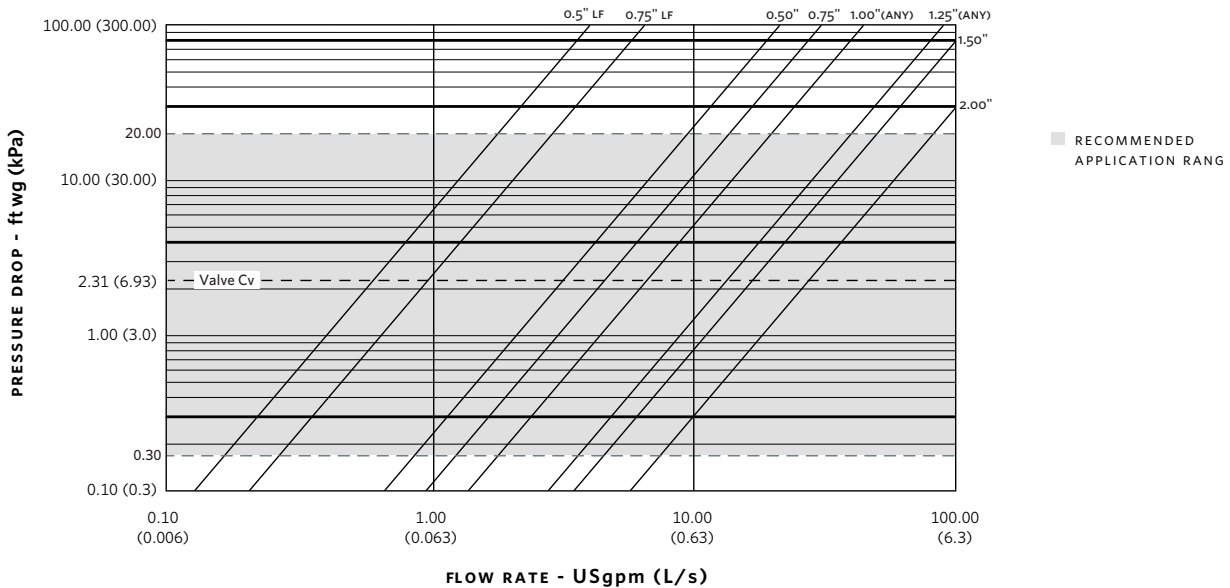

FIG. 7: These curves are for balancing contractors' use when balancing an HVAC system. For pressure drop vs. flow across the entire valve, please refer to **FIG. 8**.

COMPOSITE CURVES - FULLY OPEN VALVES

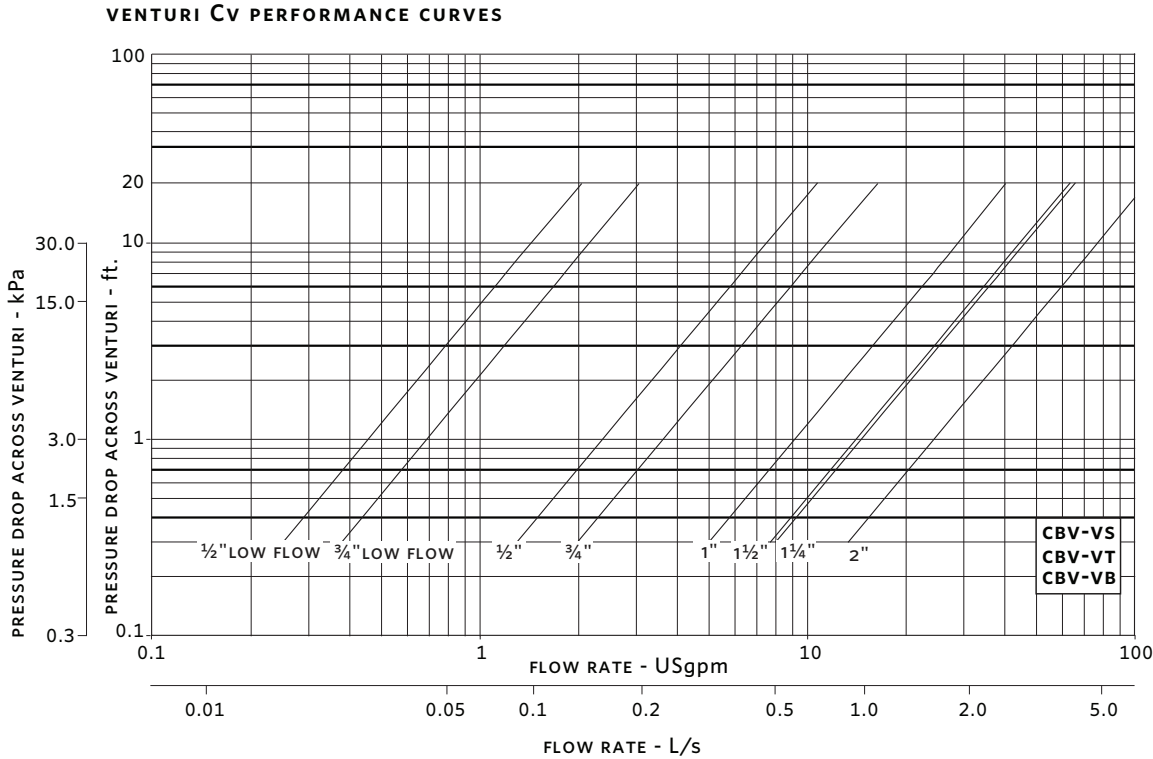

FIG. 8: These curves show the pressure drop across the ARMflo balancing valves and are for use in valve sizing. For 'pressure drop/flow' curves - required for system balancing, please refer to FIG. 7.

3.0 TROUBLESHOOTING

TORONTO
+1 416 755 2291

BUFFALO
+1 716 693 8813

BIRMINGHAM
+44 (0) 8444 145 145

MANCHESTER
+44 (0) 8444 145 145

BANGALORE
+91 (0) 80 4906 3555

SHANGHAI
+86 (0) 21 5237 0909

SÃO PAULO
+55 11 4781 5500

SYMPTOM	LIKELY CAUSE	SOLUTION
1 Valve is leaking:	At the bonnet/body joint	Bonnet O-ring has been damaged Remove the handle/stem assembly and replace with the appropriate replacement part
	At the pipe connection	If solder joint - the joint has failed, or was not soldered properly Re-solder the connection and recheck for leakage
		If threaded - the connection is not sufficiently tight, or the valve was over-tightened during installation and the valve body has cracked (fractured) Tighten and recheck for leakage Remove and reinstall a new valve, being careful not to over-tighten
2 Valve does not shut off completely when closed (hand tight)	The seat O-ring has been deformed due to overheating during soldering Remove the handle/stem assembly and replace with the appropriate replacement part indicated in the table below.	