



Evergreen® CM Indoor Blower Motor Installation Guide

Regal Rexnord
1325 Heil Quaker Blvd.
LaVergne, TN 37086
Customer Service: 800 672 6495
thedealertools.com
www.regalrexnord.com

FORM
G0131E
Revised
September 2025

⚠ WARNING indicates a hazard which, if not avoided, could result in serious injury or death.

⚠ CAUTION indicates a hazard which, if not avoided, could result in minor or moderate personal injury.

GENERAL SAFETY INSTRUCTIONS

⚠ WARNING

- Read and follow all instructions carefully.
- Disconnect and lock out the main power from the unit being serviced before installing the Evergreen CM motor. It is also a good practice to confirm that the power is disconnected with a voltmeter.
- Do not operate equipment without guards in place.
- Improper installation, adjustment, alteration, service, maintenance, or use could cause explosion, fire, electrical shock, or other conditions. Consult a qualified installer, service agency, or your distributor or branch for information or assistance. The qualified installer or agency must use the supplied or recommended parts when installing or servicing this product.
- Installation and service of this Evergreen CM motor should be performed only by trained service technicians familiar with these products.
- After installing the Evergreen CM motor, it is the responsibility of the installing technician to verify the HVAC system matches the manufacturer's requirements for proper operation, capacity, efficiency and safety.

⚠ CAUTION

- Periodic inspections should be performed. Failure to perform proper maintenance could result in premature product failure, in addition to minor or moderate injury.
- This Evergreen CM motor should be installed in accordance with accepted practices and installation instructions, and in compliance with all national and local codes.

This installation guide covers Evergreen CM indoor blower motor models 6405, 6407, 6410, 6703, 6705, 6707 and 6710.

Page 1	Application Notes
Page 2	Instructions for replacing constant torque ECM motors built with the standard plug and 24 VAC speed taps
Page 3	Start-Up and Commissioning; Electrical Connections and Operation Overview
Page 4	Diagnostics; Changing Rotation
Page 5	Mechanical Installation; Specifications and Ratings
Page 6	Technical Support

APPLICATION NOTES

1. The Evergreen CM motor is designed to replace constant torque ECM motors built with 24 VAC speed taps. This motor is also designed for use in direct drive indoor blower motor applications with forward curved (squirrel cage) blower wheels.
2. To determine the proper replacement, match the horsepower (HP) and voltage (VAC) ratings of the new motor to the failed motor. It is not necessary for the RPM or the amperage (FLA) to match.
3. **The Evergreen CM motor is pre-programmed. There is no programming necessary at the time of installation.**



6405, 6407, 6410, 6710



6703, 6705, 6707

Instructions for replacing constant torque ECM motors built with the standard plug and 24VAC speed taps.

Genteq® models X13, Endura® Pro, Ensite® Air and Evergreen® CM and EM motors



L - Line 1
G - Earth ground
N - Neutral/Line2

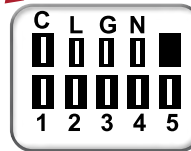

C - 24 VAC common
(1-5) 24 VAC speed taps

Evergreen® CM Motor: Installation and Connection

1. Disconnect AC power from the HVAC system. **WARNING!** Using a voltmeter, confirm the power is disconnected.
2. Disconnect the wires or plugs connected to the failed motor. If the wires are connected individually to the motor, note each wire color according to the terminal designation on the motor and/or HVAC system.
3. Install the new motor. See page 5 "MECHANICAL INSTALLATION" for mounting information, if needed.
4. Reconnect the wires or plugs from the HVAC system to the Evergreen CM motor (see diagram and information below, if needed).
5. See page 3 "START-UP AND COMMISSIONING" for information about rotation sensing and airflow selections before energizing the motor.

EASY AS 1, 2 DONE

1. Transfer wires or plugs to same connections

2. Adjust speed taps for proper demand airflow

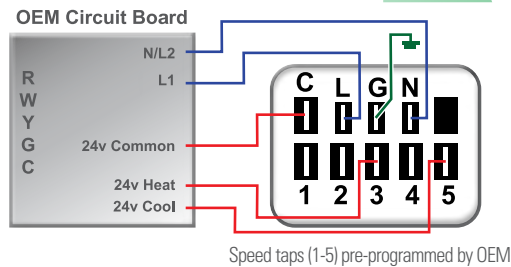

Failed Motor

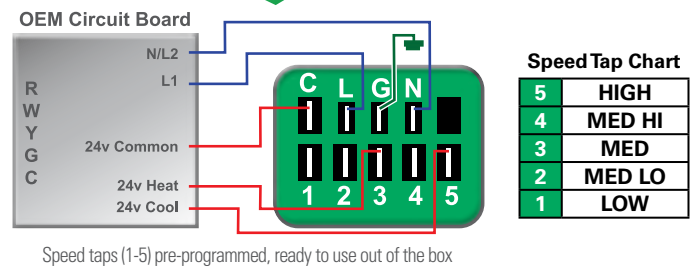

Evergreen® CM

5	HIGH
4	MED HI
3	MED
2	MED LO
1	LOW

NOTE:

The terminal size and location in the new Evergreen CM motor is identical to the motors listed on the top of this page. The original wires and/or plugs will connect to this motor at the same location as on the failed control.

START-UP AND COMMISSIONING

Rotation Sensing

The first time the Evergreen® CM motor is powered up and receives a low voltage signal on one of the speed taps, it will perform the rotation sensing process. With this feature, the motor will automatically determine the proper operating direction of the blower wheel.

NOTE: Do not bench test this motor. The first time it is energized it should be mounted in the blower housing. Do not disconnect the power from the HVAC unit until the motor continues to run in one direction for more than a minute.

During the rotation sensing process, the motor will run in both directions, up to four times if necessary, to determine the proper direction of rotation. If the proper direction cannot be determined after the fourth sequence, the motor will operate in the default direction of Counter Clockwise (CCW) as viewed from the lead end.

When the motor continues to run in one direction for more than one minute, the rotation sensing process is complete and the feature is locked out. The motor will also noticeably increase speed (up to the speed input that is powered). The motor will now operate in this direction without performing rotation sensing even if the line voltage power is disconnected. If the motor direction of rotation needs to be reversed after the rotation sensing process is complete, see page 4 "CHANGING ROTATION".

Speed Tap Selections

The speed tap VALUES (LOW-HIGH speed) of this motor may not exactly match the speed taps of the original motor. It is highly recommended to operate the HVAC system in all modes of operation. Measure airflow and adjust the speeds to match the system performance guidelines in the HVAC system's manual or unit rating plate.

NOTE: Install the system ID label, which is included with the motor kit, on the HVAC system near the existing wiring diagram.

ELECTRICAL CONNECTIONS AND OPERATION OVERVIEW

This motor is designed to be operated with continuous line voltage power. This voltage powers the electronic controls and the mechanical motor. However the motor takes its ON/OFF commands from the low voltage inputs listed below.

This motor is capable of operating from three different input types. See the chart on page 4.

- There are no ON or OFF delays with any of these input methods.
- The speed taps are built with a hierarchy. If using the 24 VAC or 18 VDC input method, you can energize multiple speed taps at the same time. The motor will always operate at the highest tap number (1-5) as labeled here and on the motor plug. See chart on next page.
- Using a PWM control (stock #760ECM), this motor can be energized and operated from 10%-100% output based on the PWM signal. It can also be controlled from a 0-10 VDC control using our 0-10 VDC harness kit (stock #5K007).

* PWM specification: The PWM signal must be a DC pulse signal with an amplitude range of 15 to 23 VDC and a frequency range of 67 to 93Hz or 127 to 199Hz to be recognized as an acceptable input by the control, 10% guaranteed on and 5% guaranteed off duty cycle.

* Connect the PWM input to the Evergreen CM motor on terminals (C) and 1.

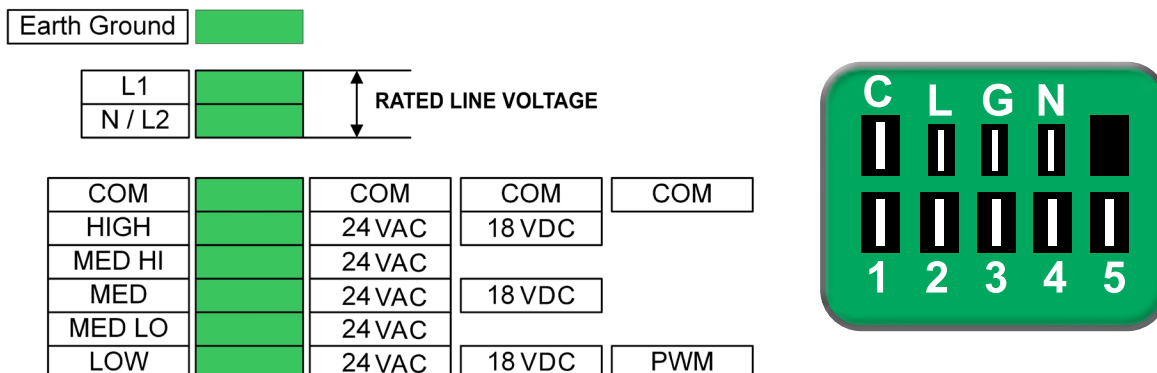

DIAGNOSTICS

If the motor does not operate:

The Evergreen® CM motor will only operate if it is receiving line voltage AND a low voltage input to one of the speed taps (see diagram on page 3).

1. Measure the voltage between terminals (L) & (N). If proper voltage is not present, solve the issue with the HVAC system controls. If proper voltage is present (voltage matching the rating on the motor), go to the next step.
2. Measure the voltage between terminal (C) and the speed tap that is currently energized. See diagram on page 3.
 - a. If the correct voltage is not present, solve the issue with the HVAC system controls.
 - b. If the correct voltage is present and the motor does not operate, the motor is failed.
Before replacing the motor please call our tech support (see page 6) if possible to confirm your diagnosis.

If the airflow needs to be adjusted:

Change the speed tap selection up or down for more or less airflow. If the highest speed is selected and there are still airflow issues:

- Measure the Total External Static Pressure (TESP). If it is higher than the HVAC unit manufacturer's guidelines, correct the airside issue.
- If the motor is operating in the wrong direction, there will be low airflow on all speed taps and very low amperage. See below for instructions to change the rotation.
- If these issues have been corrected or ruled out and there is still insufficient airflow, please call our tech support (see page 6).

CHANGING ROTATION

If the motor has been operating in one direction for more than one minute and is not operating in the correct direction continue below. If the motor has not been operating for more than a minute, energize the motor and wait for it to complete the rotation sensing process described on page 4. If the motor is operating in the wrong direction of rotation after the rotation sensing process is complete continue below.

Change rotation with the reversing harness. The Evergreen rotation reversing harness is available wherever Evergreen products are sold, catalog # 5K016. The installation instructions are included with the part.



Change rotation with onboard feature.

1. Disconnect the line voltage power to the HVAC system. **WARNING!** Using a voltmeter, confirm the power is disconnected.
2. Remove the 24 VAC inputs from speed taps numbered 1-5.
3. Create a jumper wire harness that connects speed taps 1, 3, and 5 only to a continuous 24 VAC power supply. Example: the thermostat R terminal.
 - NOTE: Do not disconnect the wires from terminals C, L, G, and N. See diagram below.
4. Restore the line voltage power to the HVAC system.
 - Line voltage power must remain on for a minimum of 30 seconds but not longer than 6 minutes. Use a watch to confirm time.
 - NOTE: The motor will operate during this timeframe.
5. Disconnect the line voltage power to the HVAC system. **WARNING!** Using a voltmeter, confirm the power is disconnected.
 - The line voltage power must remain disconnected for a minimum of 30 seconds. Use a watch to confirm time. During this time remove the jumper from terminals 1, 3, and 5 and reinstall the OEM speed tap connections.
6. Restore the line voltage power to the HVAC system. Provide any demand call to confirm that the motor has now changed direction.

If this process fails to reverse the motor's direction, repeat the above process. If this process fails to change the direction of rotation, contact Technical Support (866-503-8566).

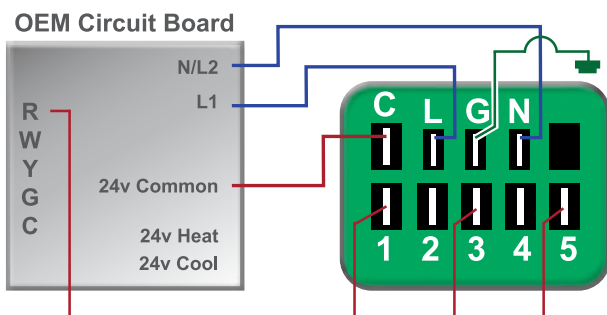

Evergreen® CM

MECHANICAL INSTALLATION

The Evergreen® CM motor is built with a NEMA®* 48 (5.6" diameter) frame for installation in a belly band mount. If the failed motor is the same frame size and the motor mount is a belly band mount, it can be reused to mount the Evergreen CM motor.

If the existing motor mount has 4 welded legs, it is likely that the Evergreen belly band motor mount stock # 5K002 will match the bolt hole configuration.



Motor Mount
5K002

The belly band should be located on the motor between the motor vents and the dimples that identify the end of the stator stack. Do not block the vents or allow the motor mount to come in contact with the electrical connection block. The 1 HP motor is built with vents on both ends of the stator stack. The motor mount should be located between the vents on the 1 HP model.

Orient the motor in the mount so that the electrical connections are facing down or at least between the 4 and 8 o'clock position, when installed in the HVAC system. When the wires are connected to the motor try to form a drip loop near the motor. This will help prevent moisture from running into the electrical connections.

NOTE: Center the blower wheel in the blower housing before tightening the hub locking bolt. Tighten the hub locking bolt on the flat area of the motor shaft.

EVERGREEN® CM SPECIFICATIONS

Voltage: 208-230/277 (acceptable operating range 180-305 VAC)

460 (acceptable operating range 414-506 VAC)

Horsepower: 277 VAC = 1/3, 1/2, 3/4, 1; 460 VAC = 1/2, 3/4, 1

Speeds: 5 @ 24 VAC, 3 @ 18 VDC, PWM

RPM: 1075 (range 600-1200)

Rotation: CW/CCW (dual rotation) rotation viewed from lead end

Bearing: Permanently lubricated ball bearing

Ambient Rating: -20°C to 55°C on 1/3 HP and 1/2 HP (non-icing conditions)

-20°C to 45°C on 3/4 HP and 1 HP (non-icing conditions)

Enclosure: Open Air Over (OAO)

Frame: NEMA®* 48 (5.6" diameter)

Shaft: Single, 1/2" diameter, 4" length, 3.5" single flat

Mounting: Belly band

UL Recognized Component

4 kV Surge Protection: Models 6405, 6407, 6410, 6710

6 kV Surge Protection: Models 6703, 6705, 6707

	VOLTAGE	STOCK #	MAX CURRENT	DIM A	DIM B
1/3 HP Model	208-230/277V	6703	2.8A	9.66"	5.74"
1/2 HP Models	208-230/277V	6705	4.1A	9.91"	5.99"
	460V	6405	2.1A	10.53"	6.61"
3/4 HP Models	208-230/277V	6707	6.0A	10.41"	6.5"
	460V	6407	3.1A	11.28"	7.36"
1 HP Models	208-230/277V	6710	7.6A	11.17"	7.25"
	460V	6410	4.0A	12.03"	8.11"

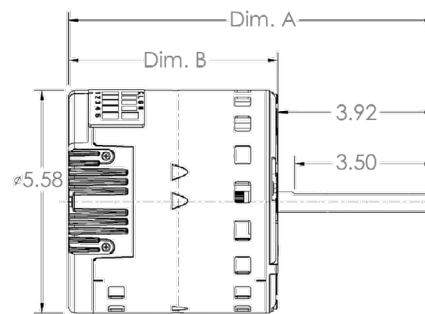

* NEMA is believed to be the trademark and/or trade name of National Electrical Manufacturers Association and is not owned or controlled by Regal Rexnord Corporation.

TECHNICAL SUPPORT

Contractor Hotline: 1-866-503-8566

Hours: M-F 8am-5pm CST

Technical support is available for Evergreen products that are installed or serviced by trained and qualified technicians familiar with the Evergreen CM motor and the HVAC system into which it will be installed.

For more information about Evergreen CM motors, scan this code with your smart phone or go to:

www.EvergreenCM-motors.com



Terms & Conditions of Sale & Limited Warranty

Sales of the products described in this Installation Manual are subject to the "Regal Rexnord Terms and Conditions of Sale." Please visit <https://www.regalrexnord.com/Terms-and-Conditions-of-Sale>.

The full Limited Warranty, including the scope and period, remedies, exclusions and disclaimers, is described in Section 10 "Limited Warranty" of the Regal Terms and Conditions of Sale and applies except as described below:

Section 10(a)(1) is replaced with the following: Seller warrants that the Products shall be delivered free from defects in material, workmanship and title. This warranty shall expire twenty-four (24) months from date of installation of the Product or thirty (30) months from date of manufacture of the Product, whichever occurs first.

The proper selection and application of products and components, including assuring that the product is safe for its intended use, are the responsibility of the customer. To view our Application Considerations, please visit <https://www.regalrexnord.com/Application-Considerations>.

To view our Standard Terms and Conditions of Sale, please visit <https://www.regalrexnord.com/Terms-and-Conditions-of-Sale>.

* NEMA is believed to be the trademark and/or trade name of National Electrical Manufacturers Association and is not owned or controlled by Regal Rexnord Corporation.

Regal Rexnord, Genteq, Endura, Ensite and Evergreen are trademarks of Regal Rexnord Corporation or one of its affiliated companies.

©2021, 2025 Regal Rexnord Corporation, All Rights Reserved. MCM-11262-GQ • Form# G0131E

The logo for Regal Rexnord, featuring a stylized 'R' icon followed by the text "RegalRexnord" in a bold, sans-serif font.