

V46 and V47

Repair Parts and Service Instructions

Part No. 24-8414-12, Rev. D
Code No. LIT-121695
Issued August 2018

Applications

The V46 pressure-actuated and V47 temperature-actuated water-regulating valves are used for water-cooled condensers, bypass service on refrigeration systems, engine cooling, and various industrial applications.

IMPORTANT: The V46 and V47 valves are intended to control liquid flow under normal operating conditions. Where failure or malfunction of the V46 and V47 valves could lead to personal injury or property damage to the controlled equipment or other property, additional precautions must be designed into the control system. Incorporate and maintain other devices, such as supervisory or alarm systems or safety or limit controls, intended to warn of or protect against failure or malfunction of the V46 and V47 valves.

Installation Guidelines

Follow these guidelines to install the V46 and V47 valves.

- Flush liquid lines to remove filings, chips, and other foreign matter before connecting to the valve.
- Make liquid line connections so the flow through the valve is in the direction of the arrow on the body casting.
- Make sure that the bulb and capillary do not rub against any metal obstruction that can wear and damage the element.
- Tighten the connector and seal, if furnished with the closed tank connector by tightening the small gland nut on heavy tubing near the bulb.
- Avoid mounting the valve where the bulb might be partly above operating liquid level or surrounded by an air pocket.
- Mount the valve vertically with the bellows facing downward.

WARNING

This product is made of a copper alloy, which contains lead. The product is therefore not to be used on drinking water.

CAUTION

Risk of Environmental Damage

Avoid sharp bends in the capillary tubes. Sharp bends can weaken or kink capillary tubes, which may result in refrigerant leaks or restrictions of flow.



Adjustments

To raise the valve opening point on direct-acting valves, turn the adjusting screw counterclockwise. To lower the valve opening point, turn the range adjusting screw clockwise. See Figure 2. The closing point of the valve is not adjustable. Pressure-actuated valves close approximately 3 to 7 psi (21 to 48 kPa) below the opening point, and temperature-actuated valves close approximately 3 to 5°F (1.7 to 2.8°C) below the opening point.

If the compressor operates in high ambient temperatures, head pressures may remain high enough during off cycles to prevent the valve from closing completely. In such instances, the opening point of the valve should be raised just enough to cause the valve to close during compressor standby periods. The opening of the valve raises the throttling point.

The all-range pressure-actuated valve settings can be adjusted for both low pressure refrigerant ranges of R-134a and higher pressure refrigerant ranges of R-22 (R-502).

Manual Flushing

To clear any sediment that may accumulate, valves may be manually flushed by inserting screwdrivers under both sides of the main spring and lifting upwards to flush the valve. Manual flushing does not affect valve adjustments.

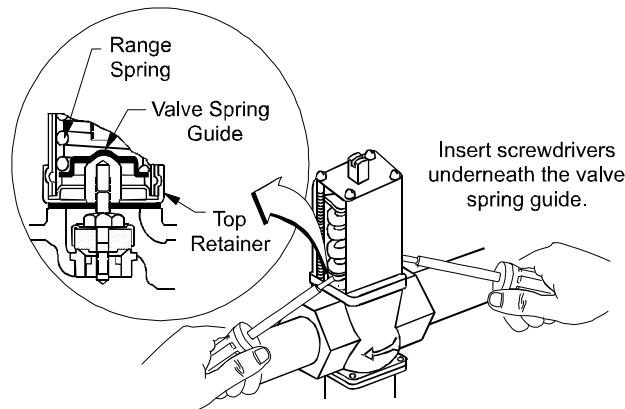

Figure 1: Manual Flushing

Inspection and Service

To inspect and replace internal parts, follow the procedures in this section.

After long periods of operation, the valve seat and rubber disc may become worn, pitted, or wiredrawn, preventing the valve from completely closing off, allowing leakage through the valve in the closed position, when the pressure and temperature is below the setpoint.

WARNING

Shut off the liquid supply and relieve pressure in the line before servicing the valve. Contents of liquid lines could be under pressure and the release of liquid under pressure may cause severe personal injury.

Note: Parts supplied in the renewal kit replace both V46 and V47 Series valve assemblies.

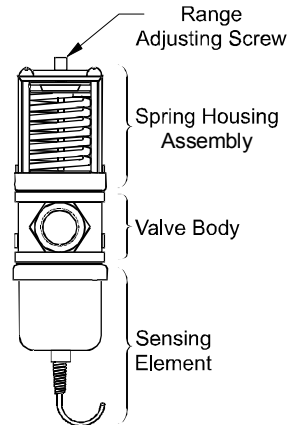

Figure 2: Valve Components

Servicing V46 and V47 2 in. and 2-1/2 in. Valve

IMPORTANT: To decrease the pressure in the sensing element on the V47 valves, cool the bulb by submerging it in ice water. Do not remove the bulb from the ice water until the element is ready to be reinstalled. Otherwise, the pressure increases in the sensing element, resulting in a valve that is hard to reassemble.

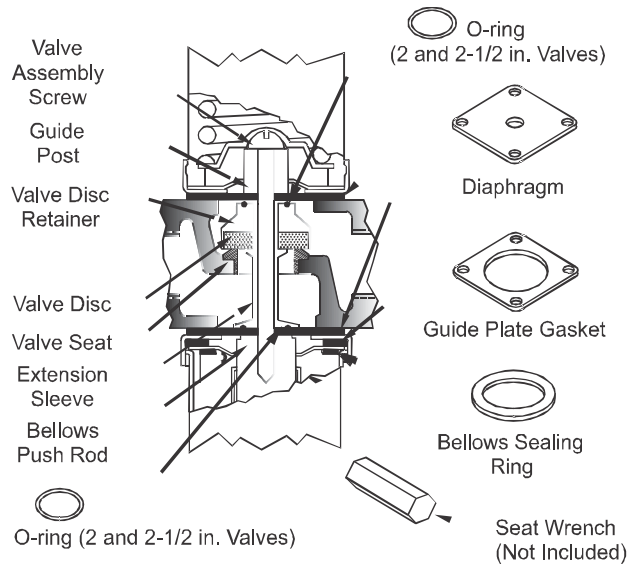

Figure 3: V46 and V47, 2 in. and 2-1/2 in.

WARNING

Risk of Personal Injury.

Protect eyes. Do not remove the two screws on the sides of the spring housing. Disassembly can cause a compressed spring to fly out and may result in serious eye injuries, blindness, or other severe injury.

1. Decrease the compression on the main spring by turning the range adjusting screw clockwise until it stops. Using excessive force to turn the screw beyond the stop point strips the thread.
2. Remove the four screws holding the spring housing and remove the entire housing assembly. See Figure 2.
3. Remove the valve assembly screw (Figure 3).
4. Remove the guide post and old diaphragms (Figure 3).
5. Remove the sensing element and the diaphragms between it and the valve body (Figure 3).
6. Pull the disc, disc retainer, and extension sleeve assembly from the valve (Figure 3).
7. Remove the old valve seat and replace it with the new valve seat (Figure 3). (A seat wrench is not provided for 2 and 2-1/2 in. valves. Use 1-1/2 and 1-15/16 in. hex stock, respectively.)
8. Replace the three diaphragms between the sensing element and valve body (Figure 4).
9. Replace the guide plate gasket and bellows sealing ring (Figure 4).
10. Assemble the sensing element to the valve body with the bellows push rod, new diaphragms, guide plate gasket, and bellows sealing ring in place.
11. Assemble the new disc, disc retainer, and extension sleeve.
 - a. Apply a small amount of grease to the grooves on the bottom of the new extension sleeve and the top of the new disc retainer. Place one O-ring into each groove.
 - b. Place the subassembly into the valve.
12. Place two new diaphragms on the spring housing end of the valve body.
13. Screw the valve assembly screw through the guide post and into the bellows push rod (Figure 3).
14. Place the spring housing assembly over the guide post and secure in place with the four housing screws.
15. Adjust the valve to desired opening point. Then manually flush the valve. See the *Manual Flushing* section.

16. Before leaving the installation, run the system through at least one complete operating cycle to be sure the valve is operating correctly.

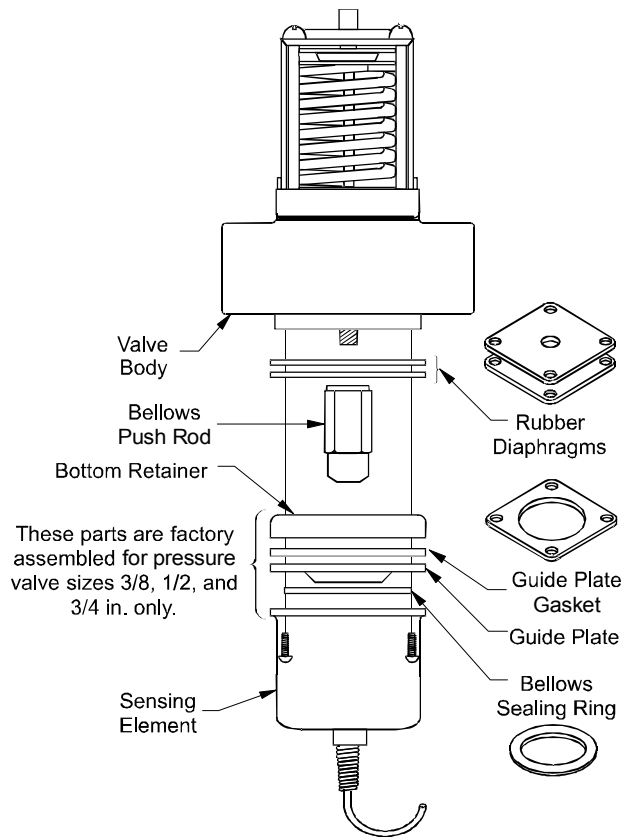

Figure 4: Guide Plate Gasket and Bellows Sealing Ring Identification

Servicing V46 and V47 3/8 in. through 1-1/2 in. Valves

IMPORTANT: To decrease the pressure in the sensing element on the V47 valve, cool the bulb by submerging it in ice water. Do not remove the bulb from the ice water until the element is ready to be reinstalled. Otherwise, the pressure increases in the sensing element, resulting in a valve that is hard to reassemble.

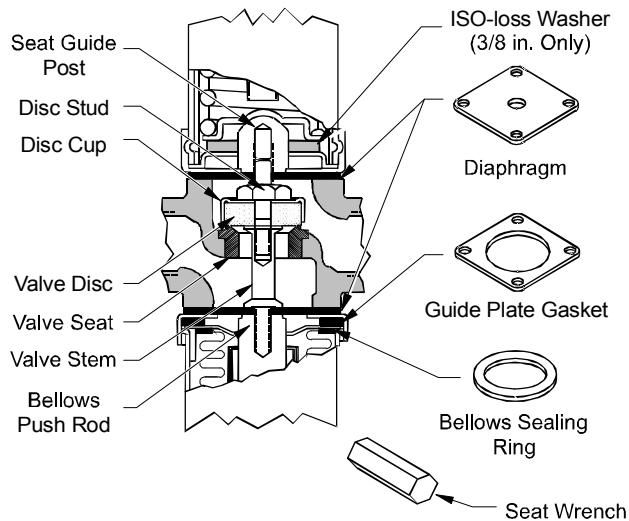

Figure 5: V46 and V47 3/8 in. through 1-1/2 in. Valves

WARNING

Risk of Personal Injury.

Protect eyes. Do not remove the two screws on the sides of the spring housing. Disassembly can cause a compressed spring to fly out and may result in serious eye injuries, blindness, or other severe injury.

1. Decrease the compression on the main spring by turning the range adjusting screw clockwise until it stops. Using excessive force to turn the screw beyond the stop point strips the thread.
2. Remove the four screws holding the spring housing and remove the entire housing assembly. See Figure 2.
3. To improve the performance on 3/8 in. direct-acting valves, install the ISO-loss washer that is supplied with the 3/8 in. valve repair kit as follows:

Note: Reverse-acting 3/8 in. valves do not require the ISO-loss washer.

- a. Slightly squeeze the spring housing assembly to remove the spring housing.
- b. Remove the range adjusting screw, spring, and valve spring guide (Figure 6).
- c. Clean off any excess grease on the valve spring guide.
- d. Place the new ISO-loss washer over the guide plate.
- e. Replace the valve spring guide, spring, range, adjusting screw, and spring housing.

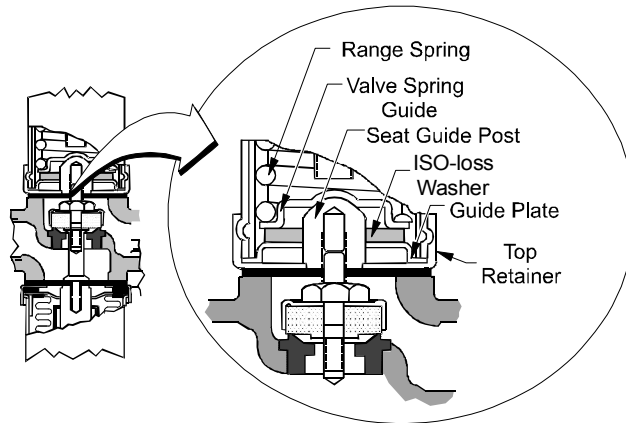

Figure 6: ISO-loss Washer

4. Remove the seat guide post (Figure 5).
5. Remove the rubber diaphragms (Figure 5).
6. Turn the disc stud counterclockwise to remove the valve stem assembly (Figure 5).
7. Remove the sensing element, bellows push rod, and diaphragms. See Figure 8.
8. Using the seat wrench supplied with the kit, remove the old valve seat and replace it with the new valve seat (Figure 5).
9. Assemble the new valve stem, disc, disc cup, and disc stud, and place into the valve body (Figure 5).
10. On 1 in. and larger pressure valves and all temperature valves, replace the guide plate gasket and bellows sealing ring (Figure 8).
11. If servicing a V47 or V46 valve other than low flow, place new diaphragms on the sensing element end of the valve stem assembly. Use two diaphragms on 3/8 in., 1/2 in., and 3/4 in. valves and three diaphragms on 1 in. and larger valves. Screw the diaphragm into place with the bellows push rod. Attach the sensing element to the valve body. See Figure 5.

12. If servicing a low flow valve, place the stem washer and new diaphragms on the sensing element end of the valve stem assembly. Use two diaphragms on 3/8 in., 1/2 in., and 3/4 in. valves and three diaphragms on 1 in. and larger valves. Screw the diaphragm into place with the bellows push rod. Attach the sensing element to the valve body. See Figure 7.

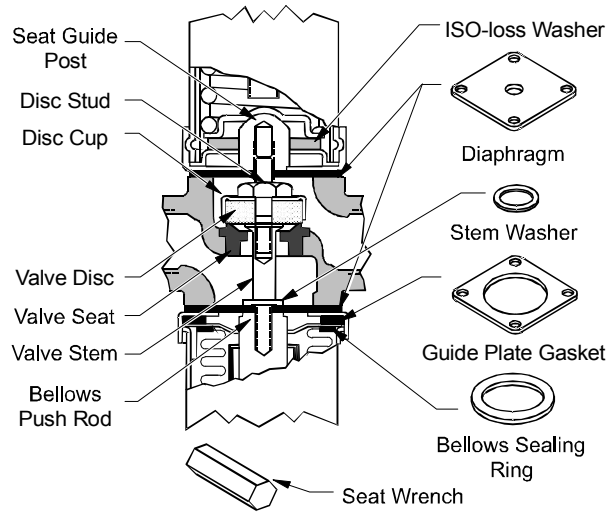

Figure 7: Low Flow Valves

13. Place two new diaphragms on the spring housing side of the valve body. Screw into place with the seat guide post (Figure 7).
14. Place the spring housing assembly over the seat guide post and secure in place with the four housing screws.
15. Adjust the valve to desired opening point. Then manually flush the valve. See the *Manual Flushing* section.

16. Before leaving the installation, run the system through at least one complete operating cycle to be sure the valve is operating correctly. Renewal Kits

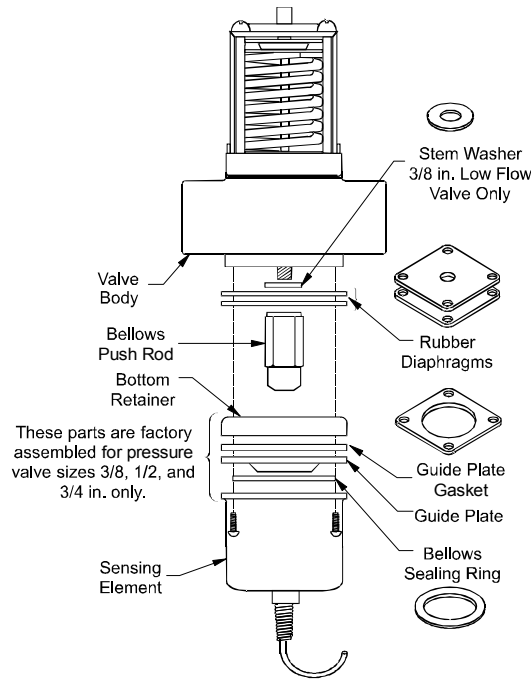

Figure 8: Guide Plate Gasket and Bellows Sealing Ring Identification

Table 1: Renew Kits (Part 1 of 2)

Individual Part Description	Commercial Type: V46A, V46D, V47A, V47N								Maritime and Navy Type: V46B, V46C					Diaphragm Kits for All Types		
	STT14A-600R 3/8 in.	STT14A-603R 3/8 in. Low Flow	STT15A-602R 1/2 in.	STT16A-601R 3/4 in.	STT17A-609R 1 in.	STT17A-610R 1-1/4 and 1-1/2 in.	STT18A-600R 2 in.	STT18A-601R 2-1/2 in.	STT14A-601R 3/8 in.	STT15A-603R 1/2 in.	STT17A-613R 3/4 in.	STT17A-611R 1 in.	STT17A-612R 1-1/4 and 1-1/2 in.	STT18A-602R 2 and 2-1/2 in.	DPM17A-600R 1, 1-1/4, 1-1/2 in.	DPM17A-601R 2 and 2-1/2 in.
Seat Guide Post	1	1	1	1	1	1			1	1	1	1	1			
Disc Stud	1	1	1	1	1	1			1	1	1	1	1			
Disc Cup (Retainer)	1	1	1	1	1	1			1	1	1	1	1			
Valve Disc	1	1	1	1	1	1	1	1	1	1	1	1	1	1		
Valve Seat	1	1	1	1	1	1	1	1	1	1	1	1	1	1		
Valve Stem	1	1	1	1	1	1			1	1	1	1	1			
Rubber Diaphragm ¹	4	4	4	4	5	5	5	5	4	4	4	5	5	5	5	5
Guide Plate Gasket	1	1	1	1	1	1	1	1	1	1	1	1	1	1	1	1
Bellows Sealing Ring	1	1	1	1	1	1	1	1	1	1	1	1	1	1	1	1
Valve Assembly Screw							1	1						1		
Guide Post							1	1						1		
Valve Disc Retainer							1	1						1		

Table 1: Renew Kits (Part 2 of 2)

Extension Sleeve							1	1						1		
Seat Wrench	1	1	1	1	1	1			1	1	1	1	1			
Sensing Element	Contact Application Engineering at (414)-524-5535															
Stem Washer		1														
ISO-loss Washer ²	1	1							1							
O-ring Seals							2	2								

1. 3/8, 1/2, and 3/4 in. valves require two diaphragms on the spring end and two diaphragms on the sensing element end. One through 2-1/2 in. valves require two diaphragms on the spring end and three diaphragms on the sensing element end.
2. Reverse acting 3/8 in. valves do not require an ISO-loss washer.

European Single Point of Contact:

JOHNSON CONTROLS
 WESTENDHOF 3
 45143 ESSEN
 GERMANY

NA/SA Single Point of Contact:

JOHNSON CONTROLS
 507 E MICHIGAN ST
 MILWAUKEE WI 53202
 USA

APAC Single Point of Contact:

JOHNSON CONTROLS
 C/O CONTROLS PRODUCT MANAGEMENT
 NO. 22 BLOCK D NEW DISTRICT
 WUXI JIANGSU PROVINCE 214142
 CHINA



www.penncontrols.com

® Johnson Controls and PENN are registered trademarks of Johnson Controls in the United States of America and/or other countries. All other trademarks used herein are the property of their respective owners. © Copyright 2018 by Johnson Controls. All rights reserved.