

## V47 Series Temperature Actuated Modulating Water Valves

### Application

The V47 modulating valves regulate the flow of water to maintain a desired temperature. V47A valves OPEN on a temperature increase at the bulb while V47N valves CLOSE on a temperature increase at the bulb. Refer to LIT-125687 for pressure actuated water valves.

The V47 temperature valves are widely used on heat exchangers to maintain optimum operating temperatures of internal combustion engines, air compressors, hydraulic oil, etc. Important benefits from the use of water valves include maximum operating efficiency of the equipment and a substantial savings effected by the conservation of water flow. They are used on condenser applications where expensive fluids are economically recovered or where the use of cooling water is restricted and on such varied applications as the temperature control of swimming pools and the control of paint temperatures on industrial printing machines.

Temperature actuated three-way diverting valves are available for special applications. Contact Customer Service for additional information.

For use with liquids other than water, contact Customer Service.

**All Series V47 water regulating valves are designed for use *only* as operating devices. Where system closure, improper flow or loss of pressure due to valve failure can result in personal injury and/or loss of property, a separate pressure relief or safety shutoff valve, as applicable, must be added by the user.**

### Features

- No close fitting sliding parts in water passages.
- Range spring does not come in contact with the cooling water.
- Easy manual flushing, if required.
- Valve design minimizes chatter and water hammer.

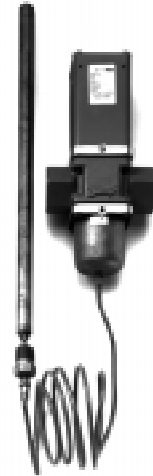

**Fig. 1 – V47 Temperature Actuated Water Valve.**

- Free movement of all parts provides smooth temperature modulation.
- Adjustment not affected by water pressure variations.
- Withstands high hydraulic shock without damage.

### General Description

A pressure-balanced design, employing synthetic rubber sealing diaphragms correctly proportioned to the valve port area, balances valves against both gradual and sudden water pressure changes, seals water away from range spring and guides and provides protection against high water surge pressures. Range spring and sliding parts are not submerged in water where they would be subject to sedimentation and corrosion. Only five metal parts, made of corrosion resistant material, come in contact with the water -- valve disc holder, disc stud, valve seat, valve stem, and body. (See Fig 2.)

### Specifications

<b>Product</b>	<b>V47</b>	Modulating Water Valves
<b>Water Supply Pressure</b>		150 PSIG (1034 kPa) Maximum
<b>Water Supply Temperature</b>		160°F (71°C) Maximum
<b>Material</b>	<b>Body</b>	3/8", 1/2", and 3/4" Sizes — Cast Brass, 1" through 2 1/2" Sizes — Cast Iron with Corrosion Resistant Finish, Naval Bronze Available, if Required
	<b>Valve Disc</b>	Buna-N
	<b>Disc Holder</b>	Commercial Valves — Brass, Naval Bronze Valves — Monel
	<b>Valve Seat</b>	Commercial Valves — Aluminum Bronze, Naval Bronze Valves — Nickel Silver
	<b>Diaphragms</b>	Nylon Reinforced Buna-N
<b>Set Point Adjustment</b>		Square Adjustment Shaft, Use a Standard Refrigeration Service Valve Wrench
<b>Mounting</b>		Vertical with Temperature Element Down

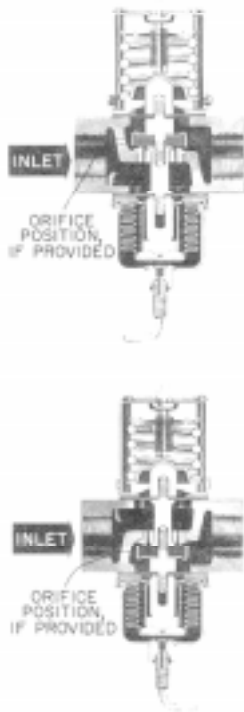

**Fig. 2 -- Typical cross-sections of threaded type valves. Interiors of flange models are similar.**

### Stock Temperature Valves

Due to many variations of temperature actuated valves, a group of standard V47 (open high) valves are maintained in stock for shipment on short notice. These valves are available in three temperature ranges and are furnished with 6 feet (1.8 m) of armored capillary and a Style 4 temperature bulb (closed tank immersion). All stock valves are supplied with a drilled and tapped internal bypass in the regulator body. A solid plug is installed in this hole for 100% shutoff. A drilled plug is packed in an envelope with each valve for field installation, if continuous minimum flow is required. (See Fig. 3.)

### Temperature Elements

Standard temperature elements are furnished with 6 ft (1.8 m) capillary. Optional capillary lengths are available on quantity orders, lengths 2 ft (.6 m), 4 ft (1.2 m), 10 ft (3 m) and longer

## Temperature Ranges\*\*

V47A Adjustable		
Standard		
Range °F (°C)	Maximum Bulb Temp. °F (°C)	Size of Valve
75 to 115 (24 to 46)	135 (57)	2", 2½"
75 to 135 (24 to 57)	155 (68)	¾" thru 1½"
115 to 160 (46 to 71)	180 (82)	2", 2½"
115 to 180 (46 to 82)	200 (93)	¾" thru 1½"
160 to 205 (71 to 96)	225 (107)	2", 2½"
160 to 230 (71 to 110)	250 (121)	¾" thru 1½"
Special (1)		
20 to 65 (-7 to 18)	85 (29)	¾" thru 1½"
40 to 85 (4 to 29)	105 (41)	½" thru 1½"
200 to 250 (93 to 121)	270 (132)	½" thru 1½"
V47N Adjustable		
Standard		
Range °F (°C)	Maximum Bulb Temp. °F (°C)	Size of Valve
85 to 130 (29 to 54)	150 (66)	2", 2½"
85 to 155 (29 to 68)	175 (79)	¾" thru 1½"
125 to 175 (52 to 79)	195 (91)	2", 2½"
125 to 200 (52 to 93)	220 (104)	¾" thru 1½"
175 to 220 (79 to 104)	240 (116)	2", 2½"
175 to 250 (79 to 121)	270 (132)	¾" thru 1½"
Special (1)		
45 to 85 (7 to 29)	105 (41)	¾" thru 1½"
55 to 100 (13 to 38)	120 (49)	½" thru 1½"
225 to 275 (107 to 135)	295 (149)	½" thru 1½"

When valve is opening a change of 3 to 5 F° (1.7 to 2.8 C°) is required to start valve closing or vice versa.

\*\* V47 open high ranges indicate the valve opening point; V47 close high ranges indicate the valve closing point.

(1) For ranges other than shown in tables consult Customer Service.

Note: On cross-ambient bulbs the bulb length will be increased 1" (25.4 mm) for each 5' (1.5 m) of capillary or fraction thereof over 10' (3.0 m).

**IMPORTANT:** Before using this chart determine type of bulb needed in particular application.

Table 1 -- Heating Bulb -- Bulb temperature is always HIGHER than bellows temperature.

Table 2 -- Cross-ambient Bulb -- Bulb temperature rises higher and drops lower than bellows temperature. Recommended for general use with standard 75 to 135°F (24 to 57°C) range to maintain control at bulb location.

**Note:** To provide satisfactory operation, always install valve with bellows down and spring cage up. Capillary end of temperature bulb should always be higher than plugged-end of bulb, or if horizontal, the word TOP should be at the top or uppermost surface of bulb.

Never subject temperature bulb to temperatures in excess of 20F° (11C°) above maximum range temperature. Example: 75 to 135°F (24 to 57°C) range; maximum bulb temperature not to exceed 155°F (68°C).

**See page 6 and 7 for Flow Chart and how To Select Water Valve Size.**

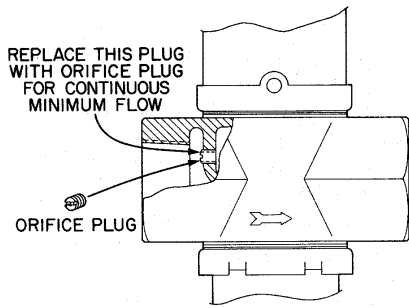

Fig. 3 — Stock temperature valve.

in increments of 5 ft (1.5 m) at extra cost. Temperature bulbs and ranges currently available are listed in Temperature Ranges and Bulb Dimension Chart. Finned air immersion type temperature bulbs, special elements and special temperature ranges are available. Consult Customer Service.

## Optional Construction

### Internal Bypass

A drilled hole is provided in valves which are actuated by temperature of water passing through the valve. Hole in valve body provides continuous bypass flow permitting temperature actuated bulb to sense temperature change. Eliminates requirement for special bypass line. Specify internal bypass hole size required. Bypass hole sizes are .035 in. (.89 mm), .062 in. (1.58 mm), .093 in. (2.36 mm), or .125 in. (3.18 mm). (See Fig. 4.)

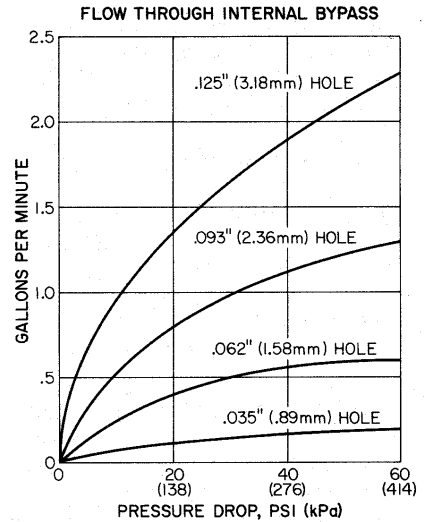
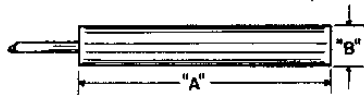

Fig. 4 — Internal Bypass chart.

## Bulb Dimensions

### Style 1 Bulb (Immersion or Surface Contact)



### Style 4 Bulb (Closed Tank Immersion)

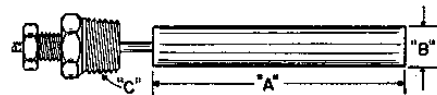

Valve Size	Table 1 — Heating Bulb			Table 2 — Cross-Ambient		
	"A"	"B"	"C" Thread*	"A"	"B"	"C" Thread*
3/8"	3 1/4" (82.6 mm)	1 1/8" (17.5 mm)	1/2" NPT	6" (152 mm)	1 1/8" (17.5 mm)	1/2" NPT
1/2"	3 1/4" (82.6 mm)	1 1/8" (17.5 mm)	1/2" NPT	10" (254 mm)	1 1/8" (17.5 mm)	1/2" NPT
3/4"	3 1/2" (82.6 mm)	1 1/8" (17.5 mm)	1/2" NPT	10" (254 mm)	1 1/8" (17.5 mm)	1/2" NPT
1"	6" (152 mm)	1 1/8" (17.5 mm)	1/2" NPT	16 1/4" (413 mm)	1 1/8" (17.5 mm)	1/2" NPT
1 1/4"	6" (152 mm)	1 1/8" (17.5 mm)	1/2" NPT	16 1/4" (413 mm)	1 1/8" (17.5 mm)	1/2" NPT
1 1/2"	6" (152 mm)	1 1/8" (17.5 mm)	1/2" NPT	16 1/4" (413 mm)	1 1/8" (17.5 mm)	1/2" NPT
2"	10" (254 mm)	1 1/8" (17.5 mm)	1/2" NPT	43" (1092 mm)	1 1/8" (17.5 mm)	1/2" NPT
2 1/2"	10" (254 mm)	1 1/8" (17.5 mm)	1/2" NPT	43" (1092 mm)	1 1/8" (17.5 mm)	1/2" NPT

\* Style 4 only.

## Bulb Wells

Bulb well dimensions	Part Number	Dimensions in		Description
		"A"	"B"	
	WEL17A-600	11.16 283.5	10.38 263.7	Copper Bulb Well, Tin Plated, Malleable Hex Connector
	WEL17A-601	9.41 239	8.66 220	Copper Bulb Well, Tin Plated, Malleable Hex Connector
	WEL17A-603	11.16 283.5	10.06 255.5	Monel Bulb Well and Connector
	WEL18A-600	4.28 108.7	3.50 88.9	Steel Well, Cadmium Plated, Malleable Hex Connector
	WEL18A-601	4.28 108.7	3.50 88.9	Monel Bulb Well and Connector
	WEL18A-602	4.28 108.7	3.50 88.9	Brass Bulb Well, Tin Plated, Malleable Hex Connector

### Stainless Steel Bulb

Models with stainless bulb, support tube, and closed tank fittings are available at extra cost on special orders.

### Mounting Bracket

Mounting bracket as illustrated in Fig. 5 available on 3/8 in. valve only when specified. Specify bracket position required. Other styles of brackets on 3/8 in. and 1/2 in. valves available on quantity orders. Consult Customer Service.

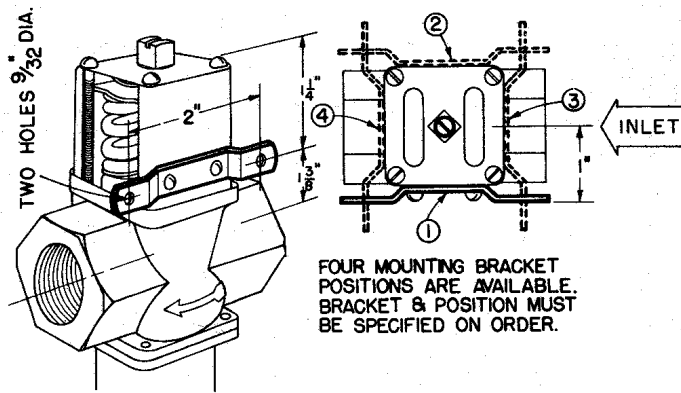

Fig. 5 — Mounting bracket for 3/8" valve. Position number 1 is illustrated at the left.

### Disc Holder, Valve Seat and Extension Sleeve

Available in monel on commercial valves at additional cost.

### Capillary Protection

Armored capillary tubing is available at additional cost (standard on stock valves).

### Manual Flushing

Valves may be manually flushed by lifting range spring follower with screwdrivers at two sides of lower spring cap to open valve. This does not change valve adjustment.

### Valves For L.P. Gas

Temperature actuated modulating valves for regulating flow of L.P. gas to crop driers or outdoor industrial equipment as shown in LIT-125695.

### Companion Flanges and Gaskets

Kits available at additional cost, when specified. For 1-1/2 in., 2 in., and 2-1/2 in. sizes -- A.S.M.E. 125 lb. standard only. Each flange kit contains two ring gaskets, two cast iron flanges, eight machine bolts and eight hex nuts. (See Fig. 6.)

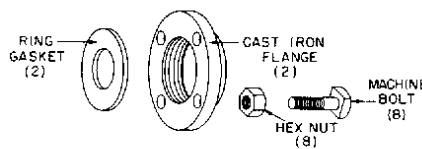

Kit No.	Water Valve Size
KIT14A-612	1 1/2"
KIT14A-613	2"
KIT14A-614	2 1/2"

Fig. 6 — Flange kit.



Fig. 7 -- A.S.M.E. flange type water valve (for flange bolt holes).

### Repairs and Replacement

Field repairs must not be made except for replacement of the sensing element, internal parts, and the rubber diaphragms. For a replacement valve or replacement parts kit, contact the nearest Johnson Controls wholesaler. Replacement part kit numbers are shown in Forms 996-57 and 996-58.

### Ordering Information

When ordering water valves, specify the following:

- Catalog Number, if established.
- If a stock valve cannot be used specify Product No. if available.
- If Product Number is not available specify the following:
  - Type Number (see "Type Number Selection Chart").
  - Temperature range required.
  - Style and size of temperature element or bulb.
  - Length of capillary tubing.
  - Fluid to be handled by valve.
- Specify special features when required, such as:
  - Internal bypass and diameter.
  - Mounting bracket (3/8 in. size only) and position on valve.
  - Monel disc holder, valve seat, and extension sleeve.

- d. Naval bronze valve body.
  - e. Armored capillary tubing.
  - f. Companion flange kit, specify Part Number.
5. Bulb well, by Part Number, if needed.

## Type Number Selection

(Commercial Valves)

For use in ordering valves other than shown in the  
Catalog Number Selection Chart.

Valve Size	Flow Coefficient With Valve Fully Open Cv (kv)	Type Number		Approx. Shipping Wt.-Lb (kg)
		Open on Temp. Rise	Close on Temp. Rise	
<b>Threaded Connection (Female NPT)</b>				
3/8	2.5 (2.1)	V47AA	V47NA	3 (1.4)
1/2	3.4 (2.9)	V47AB	V47NB	4 (1.8)
3/4	5.5 (4.7)	V47AC	V47NC	5 (2.3)
1	8.5 (7.3)	V47AD	V47ND	8 (3.6)
1 1/4	11.0 (9.4)	V47AE	V47NE	10 (4.5)
<b>Flange Connection — A.S.M.E. Specifications*</b>				
1 1/2	14.0 (12.0)	V47AR	V47NR	16 (7.3)
2	21.0 (18.0)	V47AS	V47NS	25 (11.3)
2 1/2	29.0 (24.9)	V47AT	V47NT	31 (14.1)

\*Same as American Standards Association B16 Flange Specifications for 125 lb (862 kPa) pressure. See Roughing-in Dimensions.

## Stock Catalog Valves

Catalog Number	Pipe Size NPT	Range °F (Opening Point)	Bulb Size	Bypass Orifice Diameter	Maximum Bulb Temperature (°F)	Shipping Wt. Lb (kg)
V47AA-3	3/8"	75 to 135**	1/16" x 6"	.062"	155	3.1 (1.4)
V47AB-5	1/2"	75 to 135**	1/16" x 10"	.062"	155	4.6 (2.1)
V47AC-6	3/4"	75 to 135**	1/16" x 10"	.062"	155	5.6 (2.5)
V47AD-1	1"	75 to 135**	1/16" x 16 1/4"	.093"	155	10.0 (4.5)
V47AE-1	1 1/4"	75 to 135**	1/16" x 16 1/2"	.093"	155	12.1 (5.5)
V47AR-1	1 1/2"***	75 to 135**	1/16" x 16 1/4"	.093"	155	18.0 (8.2)
V47AS-3	2"***	75 to 115**	1/16" x 43"	.125"	135	27.0 (12.2)
V47AT-3	2 1/2"***	75 to 115**	1/16" x 43"	.125"	135	33.0 (15.0)
V47AA-1	3/8"	115 to 180	1/16" x 3 1/4"	.062"	200	3.1 (1.4)
V47AB-3	1/2"	115 to 180	1/16" x 3 1/4"	.062"	200	4.6 (2.1)
V47AC-3	3/4"	115 to 180	1/16" x 3 1/4"	.062"	200	5.6 (2.5)
V47AD-2	1"	115 to 180	1/16" x 6"	.093"	200	10.0 (4.5)
V47AE-2	1 1/4"	115 to 180	1/16" x 6"	.093"	200	11.8 (5.4)
V47AR-2	1 1/2"***	115 to 180	1/16" x 6"	.093"	200	17.5 (7.9)
V47AS-1	2"***	115 to 160	1/16" x 10"	.125"	180	26.0 (11.8)
V47AT-1	2 1/2"***	115 to 160	1/16" x 10"	.125"	180	32.0 (14.5)
V47AA-2	3/8"	160 to 230	1/16" x 3 1/4"	.062"	250	3.1 (1.4)
V47AB-4	1/2"	160 to 230	1/16" x 3 1/4"	.062"	250	4.6 (2.1)
V47AC-4	3/4"	160 to 230	1/16" x 3 1/4"	.062"	250	5.6 (2.5)
V47AD-3	1"	160 to 230	1/16" x 6"	.093"	250	10.0 (4.5)
V47AE-3	1 1/4"	160 to 230	1/16" x 6"	.093"	250	11.8 (5.4)
V47AR-3	1 1/2"***	160 to 230	1/16" x 6"	.093"	250	17.5 (7.9)
V47AS-2	2"***	160 to 205	1/16" x 10"	.125"	225	26.0 (11.8)
V47AT-2	2 1/2"***	160 to 205	1/16" x 10"	.125"	225	32.0 (14.5)

All stock valves supplied with 6' (1.8 m) armored capillary and 1/2" NPT closed tank connectors. To order, specify Catalog Number only.

\* A.S.M.E. Flange.

\*\* Regularly supplied with cross-ambient bulb.

## To Select Water Valve Size

Refer to Flow Chart for selection of valves. Carefully follow steps as outlined below.

1. Determine the maximum water flow required and draw a horizontal line across upper half of Flow Chart through this flow.
2. Determine the temperature rise above the valve opening point.
  - a. Valve closing point is the highest temperature at which it is desired to have no flow through the valve.
  - b. Valve opening point will be about 5F° (2.8C°) above the valve closing point.
  - c. Determine the temperature the valve is to maintain.
  - d. Subtract the temperature opening point from the operating temperature. This gives the temperature rise.
3. Draw horizontal line across lower half of Flow Chart through this value.
4. Determine the allowable pressure drop through the valve -- this is the pressure actually available to force liquid through the valve.
5. On lower half of curve, mark point on drawn-in horizontal temperature line at pressure determined in Step 4. Interpolate between curves, or pick curve for nearest lower pressure drop for which curve is drawn (this gives a reserve maximum load capacity).
6. From this point draw line vertically upward until it intersects drawn-in horizontal water flow line in upper half of Flow Chart.
7. If intersection falls on a valve size curve this is the valve size.
8. If intersection falls between two curves the required valve size is the larger of the two.

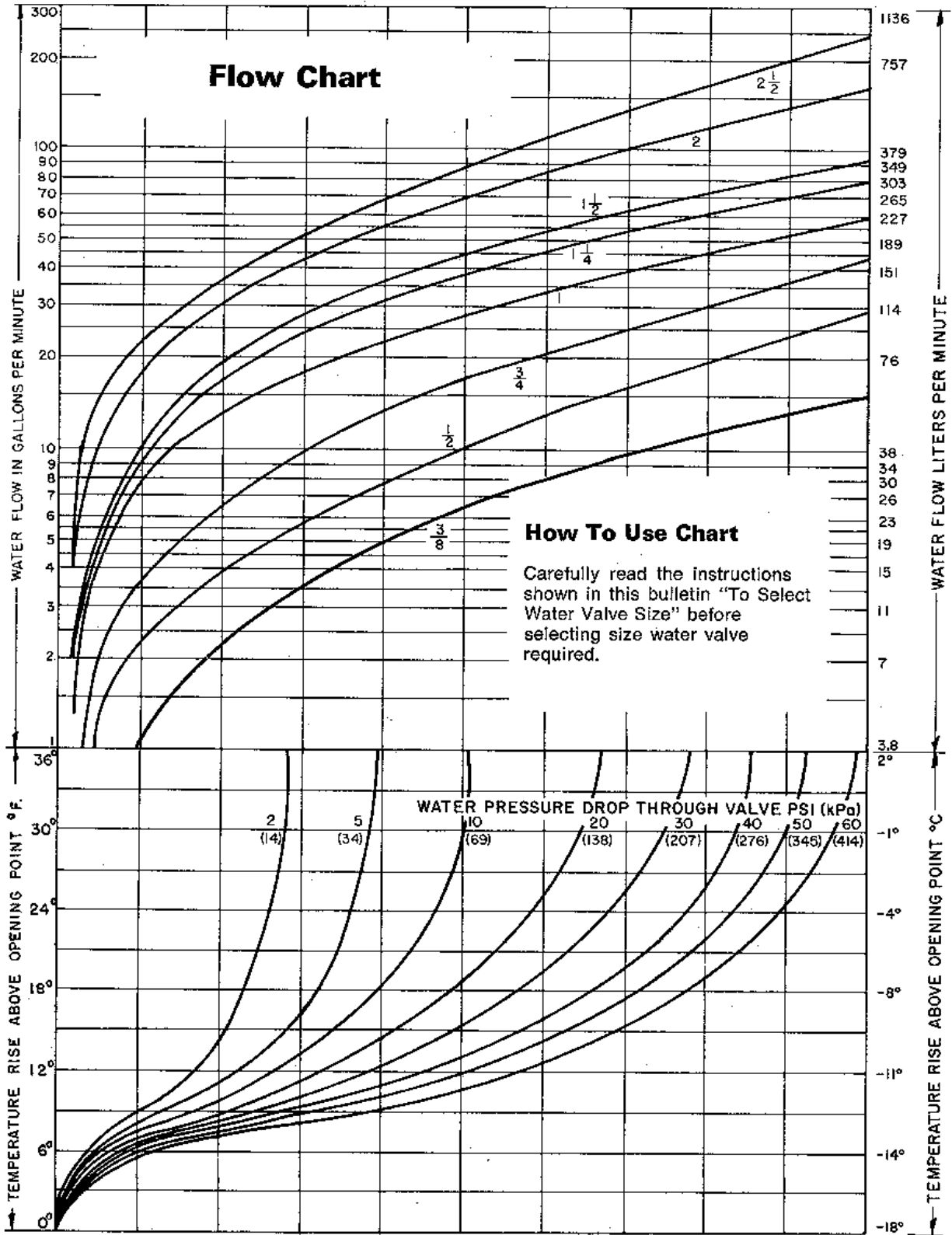

## Roughing-In Dimensions

Threaded Type  
(Cast Iron or Bronze Body)

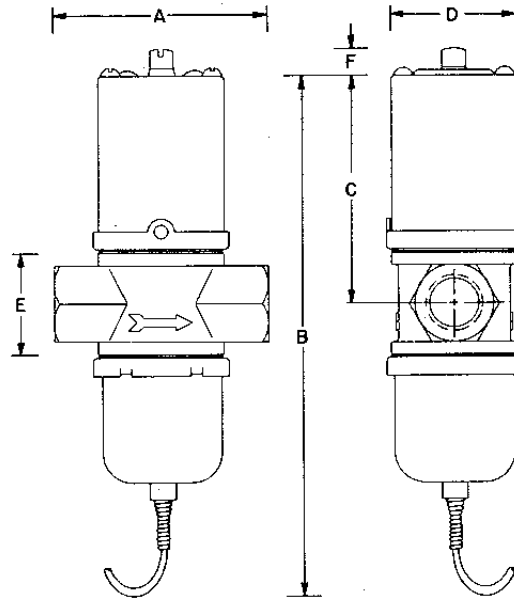

Valve Size	Dimensions in Inches					
	A	B	C	D	E	F
$\frac{3}{8}$ "	$2\frac{7}{8}$	$6\frac{11}{32}$	$3\frac{1}{8}$	$1\frac{1}{2}$	$\frac{15}{16}$	$\frac{13}{32}$
$\frac{1}{2}$ "	$3\frac{1}{8}$ ( $3\frac{15}{64}$ )*	7	$3\frac{3}{8}$	$1\frac{27}{32}$	$1\frac{1}{8}$	$\frac{13}{32}$
$\frac{3}{4}$ "	$3\frac{3}{8}$ ( $3\frac{39}{64}$ )*	$7\frac{29}{64}$	$3\frac{13}{16}$	$2\frac{1}{32}$	$1\frac{3}{8}$	$\frac{13}{32}$
1"	$4\frac{27}{32}$ ( $4\frac{57}{64}$ )*	$10\frac{19}{64}$	$5\frac{31}{64}$	$2\frac{5}{8}$	2	$\frac{1}{2}$
$1\frac{1}{4}$ "	$4\frac{55}{64}$ ( $4\frac{7}{8}$ )*	$10\frac{37}{64}$	$5\frac{43}{64}$	$2\frac{5}{8}$	$2\frac{3}{8}$	$\frac{1}{2}$

\* NOTE: Figures in ( ) are for Maritime Valves.  
All other dimensions remain the same.

**Flange Type  
(Cast Iron . . . A.S.M.E. Flange Specs.)**

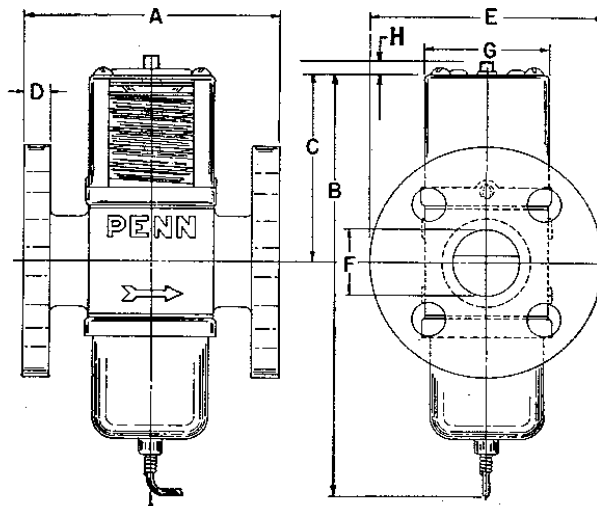

Valve Size	Dimensions in Inches							
	A	B	C	D	E	F	G	H
1½"	5 <sup>5</sup> / <sub>16</sub>	10 <sup>37</sup> / <sub>64</sub>	5 <sup>43</sup> / <sub>64</sub>	<sup>9</sup> / <sub>16</sub>	5	1 <sup>7</sup> / <sub>8</sub> Dia.	2 <sup>5</sup> / <sub>8</sub>	<sup>1</sup> / <sub>2</sub>
2"	6 <sup>5</sup> / <sub>8</sub>	12 <sup>33</sup> / <sub>64</sub>	6 <sup>15</sup> / <sub>32</sub>	<sup>5</sup> / <sub>8</sub>	6	2 <sup>1</sup> / <sub>4</sub> Dia.	3 <sup>1</sup> / <sub>2</sub>	<sup>1</sup> / <sub>2</sub>
2½"	6 <sup>3</sup> / <sub>4</sub>	12 <sup>59</sup> / <sub>64</sub>	6 <sup>1</sup> / <sub>32</sub>	<sup>3</sup> / <sub>4</sub>	7	2 <sup>3</sup> / <sub>4</sub> Dia.	3 <sup>1</sup> / <sub>2</sub>	<sup>1</sup> / <sub>2</sub>

Flange Specifications			
Valve Size	No. of Holes	Hole Size	Bolt Circle
1½"	4	<sup>5</sup> / <sub>8</sub> "	3 <sup>7</sup> / <sub>8</sub> "
2"	4	<sup>3</sup> / <sub>4</sub> "	4 <sup>3</sup> / <sub>4</sub> "
2½"	4	<sup>3</sup> / <sub>4</sub> "	5 <sup>1</sup> / <sub>2</sub> "

**Flange Type . . . Bronze Body**

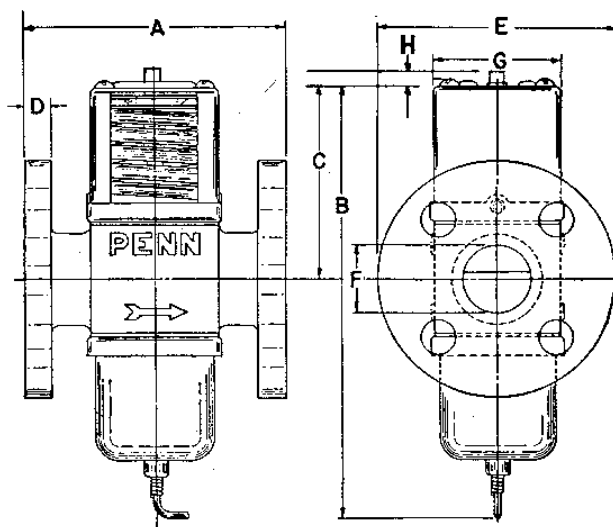

**Navy "BuShips" Service . . . Navy Flange Specifications**

Valve Size	Dimensions in Inches							
	A	B	C	D	E	F	G	H
3/4"	4 1/16	7 1/4	3 5/16	7/16	3 1/16	1 1/8	2 1/32	1/2
1"	5 1/16	8 1/2	4 1/2	1/2	4 1/4	1 1/4	2 5/8	1/2
1 1/4"	5 1/16	8 23/32	4 11/16	1/2	4 1/2	1 5/8	2 3/8	1/2
1 1/2"	5 1/16	9 23/32	4 11/16	1/2	5 1/16	1 7/8	2 3/4	1/2
2"	6 3/8	13 11/16	6 3/4	1/2	5 5/16	2 3/4	3 1/2	1/2
2 1/2"	6 3/8	13 11/16	6 3/4	1/2	6 1/8	2 3/4	3 1/2	1/2

**Maritime Service . . . A.S.M.E. Flange Specifications**

1 1/2"	5 1/16	10 37/64	5 49/64	5/16	5	1 1/8 Dia.	2 5/8	1/2
2"	6 3/8	12 33/64	6 15/32	1/2	6	2 3/4 Dia.	3 1/2	1/2
2 1/2"	6 3/4	12 33/64	6 15/32	1 1/16	7	2 3/4 Dia.	3 1/2	1/2

**Flange Specifications**

**Navy "BuShips" Service . . . Navy Flange Specifications**

Valve Size	No. of Holes	Hole Size	Bolt Circle
3/4"	4	9/16"	2 11/16"
1"	4	9/16"	3 1/8"
1 1/4"	4	9/16"	3 3/8"
1 1/2"	6	9/16"	3 11/16"
2"	6	9/16"	4 7/16"
2 1/2"	6	9/16"	5"

**Maritime Service . . . A.S.M.E. Flange Specifications**

1 1/2"	4	5/8"	3 3/8"
2 1/2"	4	3/4"	5 1/2"

*Performance specifications appearing herein are nominal and are subject to accepted manufacturing tolerances and application variables.*

---

## Notes

---

# Notes



**Controls Group**  
507 E. Michigan Street  
P.O. Box 423  
Milwaukee, WI 53202

Printed in U.S.A.