



INSTALLATION INSTRUCTIONS

133-667

MicroM MEP237 with Integrated Phoenix and InSight Scanners



The MicroM programmer, MEP237, with the MEDC2 amplifier, is specially designed to operate as a primary burner control and connect to the specific types of the integrated InSight and Phoenix scanner as a flame detector. **Refer to bulletins MC-5000, CU-95 and CU-105 for detailed operational information.**

The Fireye MicroM Series Flame Safeguard Control is a compact, microprocessor based, modular burner management system designed to provide automatic ignition and continuous flame monitoring for commercial sizes of heating and process equipment firing any type of fuel.

The FIREYE InSight Type 95IR, 95UV, and 95DS flame scanners are micro-processor based flame scanners utilizing solid state infrared (IR) or ultraviolet (UV) or dual (IR and UV) sensors. The FIREYE InSight Type 95 flame scanners incorporate an internal flame relay with adjustable ON/OFF thresholds. The InSight scanners incorporate elements of the FIREYE Type 45FS1 and 45UVFS1 Signature Scanners™ as well as of the Type 45RM4 flame scanners to detect the presence or absence of a target flame in single or multi-burner applications.

The InSight scanners measure the amplitude of the modulations (the flame "flicker") that occur within the targeted flame. During the scanner set-up procedure, the modulation frequency that yields the best flame ON/OFF discrimination is selected. The appropriate modulation frequency and sensor gain is either manually selected (S1 models), or automatically selected with manual override capability (S2 models).



In order to meet compliance with national and local codes, the InSight scanner must have its FFRT (flame failure response time) set to no more than 3 seconds.

The Standard Model S1 has three choices of modulation frequency, adjustable sensor gain, adjustable flame relay ON/OFF thresholds, 4-20 mA analog signal strength output, fault relay, and two selectable programmable files to store setpoints (for two different fuels or firing rates).

The Expanded Model S2 adds automatic programming (AutoTune) with manual override capability, 21 choices of flame flicker frequency, a total of four selectable programmable files to store setpoints, plus adds remote communication capability via Fireye Windows 95/98/NT user software. All FIREYE InSight scanner models are powered by 24 Vdc and contain electronic self-checking (no mechanical shutter required). The scanners contain an eight character alpha-numeric LED display and a four (4) push-button keypad to enable the user to view operating parameters and select setpoints.



The Fireeye Phoenix scanner types 85UVF4-1WR, 85IRF4-1WR, 85UVF4-1EX-WR, 85IRF4-1EX-WR, 85UVF4-2WR and 85IRF4-2WR are unique versions of the standard Phoenix microprocessor based devices specifically designed to interconnect and operate with Fireeye Flame Safeguard Controls. The -1EX versions are rated for installation in hazardous locations. The -2WR are fiber optic versions of the standard models.

The Phoenix flame scanners incorporate an internal flame relay with automatically set ON/OFF thresholds. Phoenix scanners detect the amplitude of the modulations (the flame "flicker") that occur within the targeted flame, over a wide frequency. During the scanner set-up procedure, the amplitudes of the target flame are automatically stored by the flame scanner, together with optimum ON/OFF criteria. The appropriate sensor gain is automatically selected. Phoenix scanners incorporate full self-diagnostics and electronic self-checking.

All models of the Phoenix flame scanners are housed within an engineered material making them incredibly strong but lightweight and easy to handle. The housing material is designed to meet the requirements of NEMA 4X (IP66).

The Insight scanner housing is cast aluminum with gray polyester powder coat finish and meets NEMA 4X (IP66).

Refer to bulletins CU-105 and CU-95 for exact scanner environmental classifications.

The Phoenix and Insight flame scanners are powered by 24Vdc (supplied separately). The 24 Vdc supply must be powered from the same mains supply as the MicroM. See wiring diagrams.

SCANNER ORDERING INFORMATION

PHOENIX	
85UVF4-1WR	Phoenix Integrated Scanner, 4 sec FFRT – Ultra-violet with 10 foot cable. FM, UL_CUS approved.
85UVF4-1EX-WR	Phoenix Integrated Scanner, 4 sec FFRT – Ultra-violet with 10 foot cable. FM, UL_CUS approved, suitable for hazardous locations. See bulletin CU-105.
85UVF4-2WR	Fiber optic version of standard Phoenix Integrated Scanner, 4 sec FFRT – Ultra-violet with 10 foot cable. FM, UL_CUS approved.
85IRF4-1WR	Phoenix Integrated Scanner, 4 sec FFRT – Infrared with 10 foot cable. FM, UL_CUS approved.
85IRF4-1EX-WR	Phoenix Integrated Scanner, 4 sec FFRT – Infrared with 10 foot cable. FM, UL_CUS approved, suitable for hazardous locations. See bulletin CU-105
85IRF4-2WR	Fiber optic version of standard Phoenix Integrated Scanner, 4 sec FFRT – Infrared with 10 foot cable. FM, UL_CUS approved.
35-318-1	Mounting flange for Phoenix, 1" NPT
35-318-2	Mounting flange for Phoenix, 1" BSP
INSIGHT	
95IRS1-1	Standard Model InSight Scanner – Infrared with quick disconnect, FM, CSA approved.
95UVS1-1	Standard Model InSight Scanner – Ultra-violet with quick disconnect, FM, CSA approved.
95DSS1-1	Standard Model InSight Scanner – Dual detector with quick disconnect, FM, CSA approved.
95IRS2-1	Enhanced Model InSight Scanner – Infrared with quick disconnect, FM, CSA approved.
95UVS2-1	Enhanced Model InSight Scanner – Ultra-violet with quick disconnect, FM, CSA approved.
95DSS2-1	Enhanced Model InSight Scanner – Dual detector with quick disconnect, FM, CSA approved.
60-2692	1" NPT mounting flange for InSight Scanner, includes heat insulator 35-127-1.
60-2693	1" NPT mounting flange for InSight Scanner, includes heat insulator 35-127-3.
CABLES	
59-497-020-WR	Cable, using 59-497 with straight connector (129-164), 20 feet.
59-497-020C-WR	Cable, using 59-497 with straight connector (129-164C) and flex conduit adapter, 20 feet.
59-497-020R-WR	Cable, using 59-497 with right angle connector (129-164R), 20 feet
59-497-020RC-WR	Cable, using 59-497 with right angle connector (129-164RC) and flex conduit adapter, 20 feet
POWER SUPPLIES	
60-2685-2	Power Supply, 24 VDC, 2.1A, 120/240 VAC
60-2685-4	Power Supply, 24 VDC, 4.2A, 120/240 VAC



The MicroM MEP237 is equipped with a set of dip switches and a run/check switch and provides the following operational characteristics:

1. Intermittent pilot operation.
2. Purge time: dip switch selectable, 7, 30, 60 or 90 seconds.
3. Pilot trial for ignition period (PTFI): Dip switch selectable 5 or 10 seconds fixed.
4. Action on pilot flame fail: Lockout.
5. Action on main flame fail: Dip switch selectable, recycle or non-recycle.
6. Action on air flow (interlock) open: Recycle.
7. Action on air flow (interlock) not closing: Indefinite hold.
8. Action on jumped air flow (interlock) at start: Dip switch selectable.
9. Run/Check switch provided for pilot trial for ignition period
10. Post purge time after operating limit or interlock opens: Dip switch selectable, 0 or 15 seconds.
11. Post purge time after flame fail during PTFI and AUTO period: 15 seconds.
12. Able to detect shorted scanner cable.
13. With MEDC2 amplifier, provides flame failure response of 0.25 seconds.

Below is the timing sequence of the MEP237 as it would operate through a normal cycle.

FUNCTION	TRM	STANDBY		PURGE	PTFI	AUTO	POST PURGE	CYCLE COMPLETE
				7-90 SECONDS	5/10 SECONDS		0/15 SECONDS	
OP CTRL	7							
AIR FLOW	6							
BLOWER	8							
PILOT	3							
IGNITION	4							
MAIN	5							
FLAME SIGNAL								

OPERATOR & SYSTEM INTERFACE

Local interface to the Phoenix scanner is via a pushbutton keypad and information LEDs. These provide continuous indication of flame signal, flame relay status, scanner status as well as selected mode of operation. Simplified keystroke routines are used for set up and can be completed in seconds. For remote interface, outputs are provided for fault relay and 4 to 20mA flame strength, in addition to the flame signal connection for the Fireye programming controller.



PHOENIX WIRING DIAGRAM

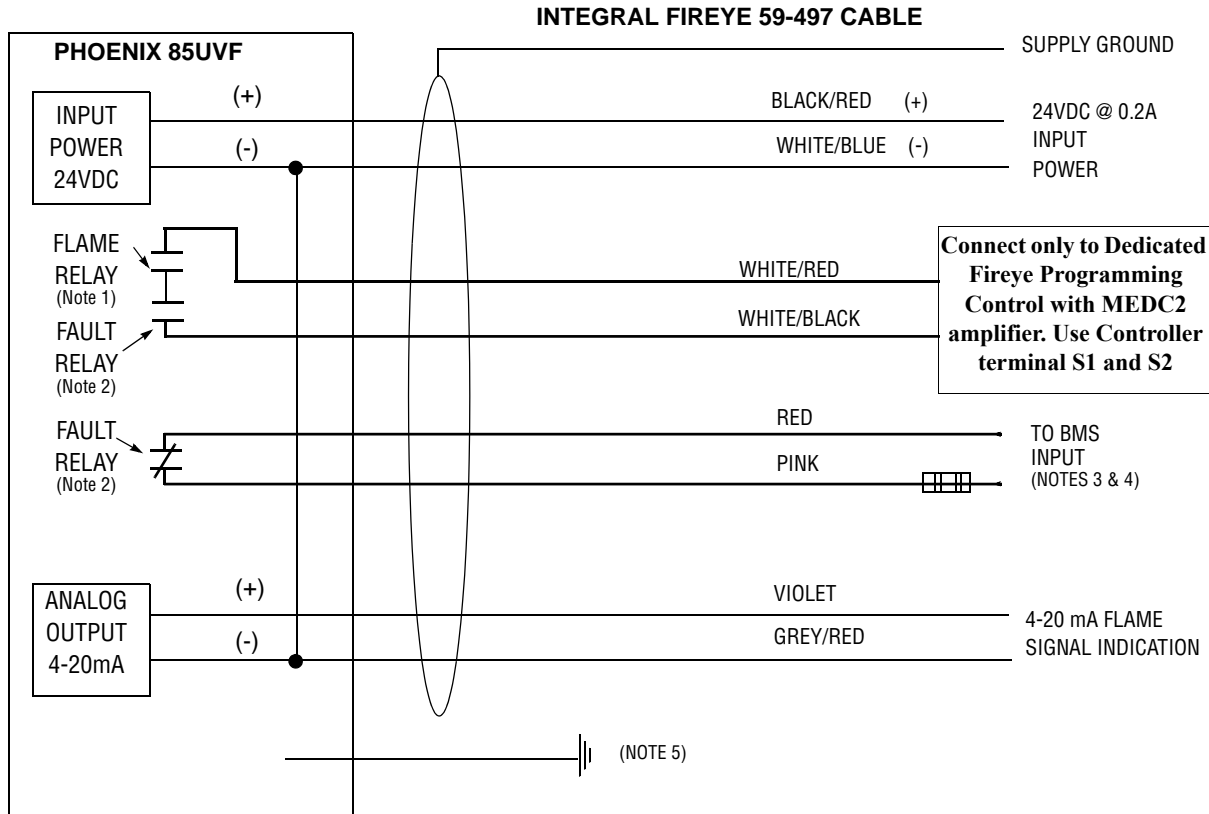

Notes:

1. Flame relay contacts are shown in the de-energized (no flame condition).
2. Fault relay contacts are shown in de-energized (fault) condition.
3. BMS = Burner Management System (by others). Do not use Grey/Red as 24 volt ground.
4. External 2.0 Amp fuses recommended.
5. A safety ground screw is provided on the scanner end plate. An external ground wire must be installed if line voltage is applied to the relay contacts.

INSIGHT WIRING DIAGRAM

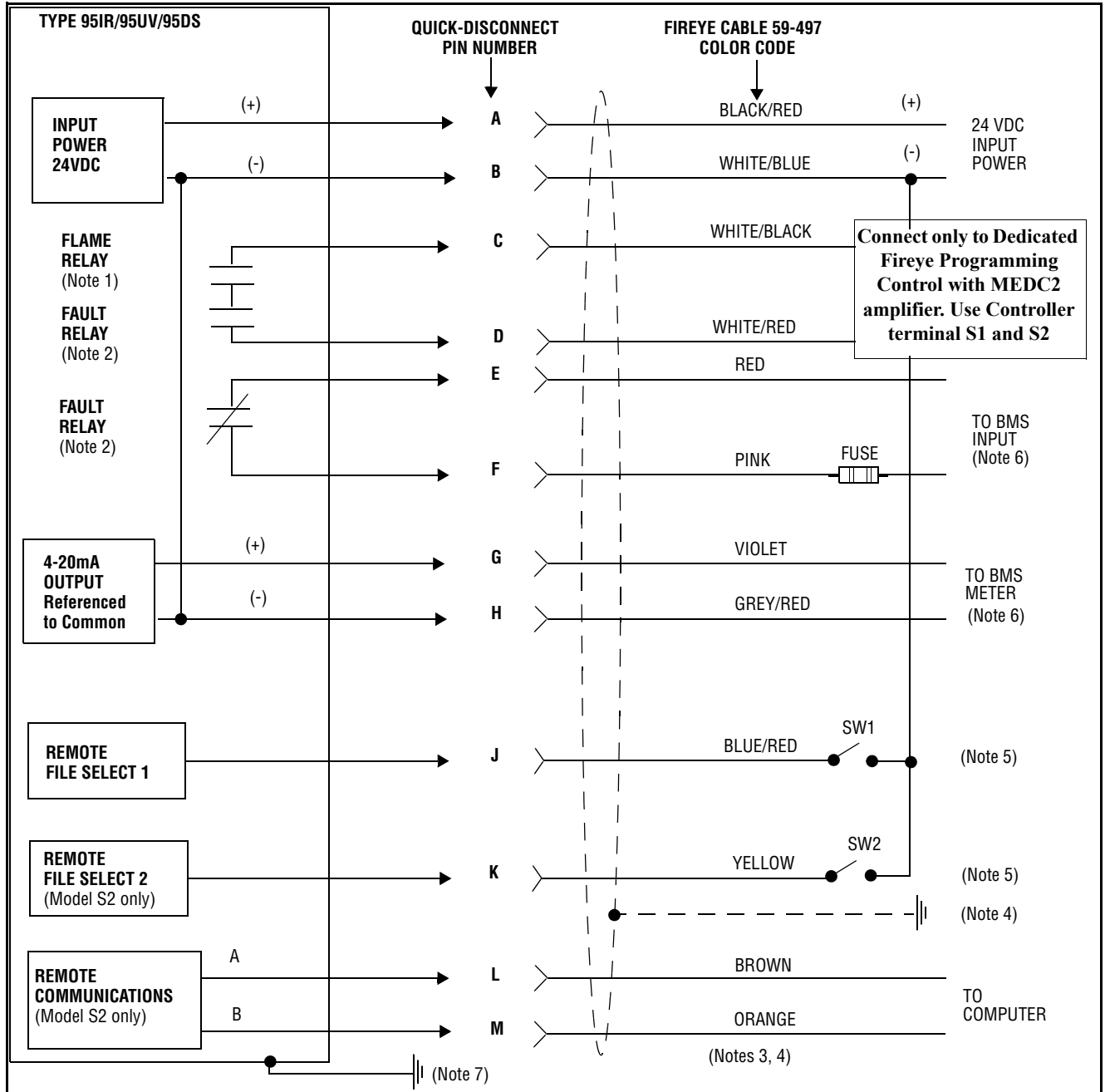

Notes:

1. Flame relay contacts are shown in de-energized (no flame) condition.
2. Fault relay contacts are shown in de-energized (fault) condition.
3. Brown and orange wires are a twisted pair.
4. **Connect cable shield to earth ground at power source.**
5. With Remote File Select programmed as "LINE", external switches SW1/SW2 (not furnished) will select between two (S1 Models) or four (S2 Models) internal memory files, when connected to 24Vdc (-) supply.
6. External 2.0 Amp fuses recommended.
7. **A ground screw is provided on the scanner end plate. An external ground wire must be installed if line voltage is applied to the relay contacts.**

MicroM WIRING DIAGRAM

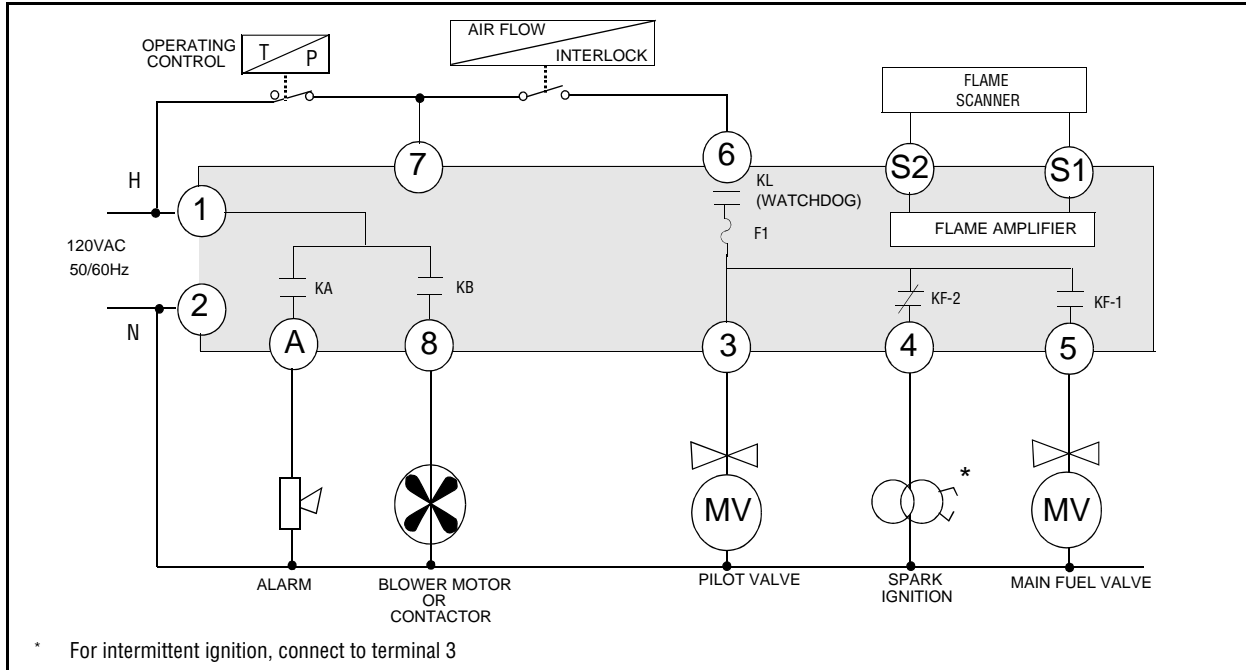

Normal Operation

With power applied and the limit operating control circuit (1-7) closed, the Operating Control LED illuminates, the burner motor circuit is energized (Terminal 8).

After the air flow proving switch (7-6) closes, the interlock (air flow) LED is illuminated and a time pre-purge delay dependent on the dip switch setting begins.

At the expiration of the safe start check period, a 10 second pilot trial for ignition (PTFI) period is initiated, illuminating the PTFI Led. Power is applied to Terminal 3, energizing the pilot gas valve and to Terminal 4, energizing the spark ignition.

At the detection of pilot flame, the FLAME LED is illuminated, and the programmer holds that position for 3 seconds to allow the pilot to stabilize.

Power is then applied to Terminal 5 energizing the main fuel valve and removing power from Terminal 4, turning off the spark igniter.

When the operating control opens, the control de-energizes Terminal 3 and Terminal 5 and the programmer reverts back to an Idle state.

INITIAL SETUP

The MEP237 provides a RUN / CHECK switch that halts the programmer during the Pilot Trial for Ignition period. The MicroM will keep the pilot valve (3) and ignition transformer (4) energized during this period. In order for the Insight or Phoenix scanner to provide a contact closure to the MicroM, it must first be placed in the learn mode during the pilot establishing period. **Refer to bulletin CU-95 and CU-105 for the Insight and Phoenix learn procedures.** During the CHECK mode the MicroM provides up to 30 seconds of no flame signal to have the INSIGHT and PHOENIX scanner learn the pilot flame signal. After successfully learned the MicroM can be placed in the RUN mode to advance to the main flame or AUTO stage.





FIREYE®
3 Manchester Road
Derry, New Hampshire 03038 USA
www.fireeye.com

133-667
MAY 4, 2007
Supersedes March 19, 2007